



ST. CLAIR CATHOLIC
DISTRICT SCHOOL BOARD

Lighting the Way ~ Rejoicing in Our Journey

TENDER NUMBER: 634-CP1914

Roof Replacement Project

St. Joseph Catholic School

535 Birchbank Drive, Corunna, ON N0N 1G0

Submission Deadline and Location:

Tuesday, April 9, 2019

2:00:00 PM Local Time

Reception Desk, Catholic Education Centre

420 Creek Street, Wallaceburg, ON N8A 4C4

1. BID SUBMISSION

The St. Clair Catholic District School Board (Board) is seeking a roofing contractor to provide all of the necessary materials, equipment and labour to complete roof replacement project at St. Joseph Catholic School located at 535 Birchbank Drive in Corunna, ON.

Bids shall be submitted with the project clearly identified on the sealed envelope:

Bid Package #: 634-CP1914 – St. Joseph Catholic School, Corunna – Roof Replacement Project.

The sealed Bid Submission must be returned to:

Catholic Education Centre, 420 Creek St. Wallaceburg, ON N8A 4C4

Attention: Mr. Tony Prizio, Supervisor - Procurement

No later than Tuesday, April 9, 2019 @ 2:00:00 p.m.

Any bid submissions received after the deadline will be returned unopened to the bidder. (No extensions to Bid Closing date are anticipated. Bidders are encouraged to act immediately to prepare their submissions!) The Board will not take any responsibility for late submissions due to postal delay through Canada Post or other courier services.

Bids shall be filled out in ink or typed, signed in longhand by a duly authorized company official (having authority to bind) and sealed with a company corporate seal. One original of the fully completed Bid Form must be submitted. Failure to provide all of the requested information on the Bid Form may result in disqualification of the bid.

Bids by telephone, email, or fax will not be accepted.

After bid closing all submissions will be reviewed by the Board's evaluation team. Contractors submitting a bid are invited to stay for a public opening of Bids at 2:05 pm at the Catholic Education Centre.

Supplier's Bid Submission, all Bid Documents and Purchase Order will form the agreement.

2. SCOPE OF WORK

The Instructions to Bidders identifies the work to be performed in the Contract and takes priority if there is a conflict within the Bid Documents. The detailed scope of work, specifications, and drawings are attached to this document.

3. BID DOCUMENTS

Instructions to Bidders, Bid Form, Specifications & Drawings, Supplementary Conditions, Appendices & Tender Specific Requirements, and Addenda will form the Bid Documents. Prime Contract will be a Purchase Order.

Bid Documents are available on the Board's Website www.st-clair.net under Bid Opportunities and on Biddingo www.biddingo.com, along with the Sarnia Construction Association, Windsor Construction Association, Lambton Area Builders Exchange and the London & District Construction Association.

The Board assumes no responsibility for the bidder's failure to examine **all** of the Bid Documents.

4. VOLUNATRY ALTERNATE & SEPARATE PRICES

The bid amounts are to be based on the bid documents. Where there is any conflict within the bid documents, the bid amount shall include the higher cost alternative. Alternative proposals are encouraged and must be identified in the bid. Submit complete information including any impact on schedule to allow a full evaluation of the proposal including, as applicable, any particulars in which the alternate proposal is at variance with or unable to meet the specifications. Note also any impact on other trades if the alternative is accepted. Alternative proposals may be made without limitation, including for items specified as single sourced.

5. BID ACCEPTANCE

It shall be understood by all bidders, that the bid shall be valid and subject to acceptance by the Board, and that no adjustments shall be made to the Bid amounts for a period of up to and including sixty (60) days from the Bid Closing Date.

The Board reserves the right to determine the successful bidder by any combination of base bid, separate prices, requested alternate prices and voluntary alternate prices submitted with the bid. The Board is not obligated to select the bid with the lowest price and may cancel a bid prior to award without liability to any bidder.

The successful bidder shall be required to enter into a formal contract with the Board, which will include the terms and conditions of the Instructions to Bidders, Bid Form, and all other applicable documents.

6. BID INELIGIBILITY

Bids that are unsigned, improperly signed or sealed, conditional, illegible, obscure, contain arithmetical errors, erasures, alterations, or irregularities of any kind may, at the discretion of the Owner, be declared informal.

Bids with Bid Forms and enclosures which are improperly prepared may, at the discretion of the Owner, be declared informal.

Bids that fail to include the security deposit, consent of surety may, at the discretion of the Owner, be declared informal.

Bids based on prices seeming to be so unbalanced as to adversely affect the interests of the Owner may, at the discretion of the Owner, be declared informal.

Bids based upon an unreasonable period of time for completion of the Work may, at the discretion of the Owner, be declared informal.

Bids that do not include Proof of Insurance may, at the discretion of the Owner, be declared informal.

7. AWARD

The Board has the right to reject any or all bids. The lowest Bid will not necessarily be accepted. The invitation to bid does not constitute an offer by the Contractor to enter into a contract. Acceptance of the Bid and/or award is subject to the approval of the St. Clair Catholic District School Board.

In the event of a tie, a coin flip conducted by the Supervisor – Procurement (or designate) with a minimum of one other Board staff will determine the successful proponent.

8. ENTITLEMENT TO A DEBRIEFING

In accordance with the Broader Public Sector Procurement Directive unsuccessful Bidders are entitled to a debriefing, during which they will be provided with feedback regarding their Tender. In order to be debriefed, unsuccessful Bidders must contact the Owner representative identified on the Communications Notice in writing to request a debriefing within sixty (60) days from the date of the notification of award.

9. BID DISPUTE PROCEDURE

In the event that a Bidder wishes to review the decision of the Board in respect of any material aspect of the Request For Tender process, the Bidder shall submit a protest in writing to the Board to the attention of the Supervisor – Procurement within ten (10) days of the closing date of the Tender.

Any protest in writing shall include the following:

- a) a specific identification of the provision and/or procurement procedure that is alleged to have been breached;
- b) a specific description of each act alleged to have breached the procurement process;
- c) a precise statement of the relevant facts;
- d) an identification of the issues to be resolved;
- e) the Bidder's arguments and supporting documentation;
- f) the Bidder's requested remedy.

10. INVOICING & PAYMENT

The Board shall pay by electronic funds transfer (EFT), P-Card, or cheque within thirty (30) days after the receipt of a proper invoice. Invoices will be reviewed and certified by the Board's Consultant, if applicable, before the invoice is processed for payment. Invoices must include all back-up material for time and material charges, disbursements, and other fees. Please make reference to the Purchase Order number on the invoice.

Note: Invoices should reflect a 10% holdback (final construction cost) which will be retained by Board through substantial completion of the project.

Invoices should be sent digitally to facility.services@st-clair.net. Digital invoices will be processed as an original. Please do not send copies by mail.

11. TAXES

Include in Bid all Taxes and all other Customs Duties and Excise Taxes which are in force at Bid date as detailed in General Conditions. Harmonized Sales Tax (H.S.T.) is **not** to be included in the bid. The H.S.T. amount and the Bidder's **H.S.T. Registration Number** are to be indicated on the Bid Form in the spaces provided.

12. ADDENDA

Bidders finding discrepancies, ambiguities or omissions in the bid documents or having doubt as to the meaning or intent thereof, shall immediately notify the Procurement Department who may issue instructions and/or clarifications by Addendum to all Bidders. Bidders may also, during the Bidding Period,

be advised by Addendum of any additions, deletions or alterations to bid documents. All such Addenda shall become part of the Bid Documents.

All questions must be addressed in writing to: Victoria Iaccino, Procurement Officer
St. Clair Catholic District School Board
E-mail: victoria.iaccino@st-clair.net
CC: tony.prizio@st-clair.net

Questions must be received by Thursday, March 28, 2019 @ 12:00 pm. Answers will be provided by way of addendum no later than Tuesday, April 2, 2019.

If an addendum is issued, the document(s) will be made available to bidders through the same platform that the original bid document were issued. Bidders are responsible for verifying before submitting its response that it has received all addenda that may have been issued.

13. CHANGE NOTICES, CHANGE ORDERS

The following fee percentage and overhead charges shall be applied to additional work ordered by the Board:

- For work carried out by the Contractor's own forces – 10% Overhead & Profit
- For work involving a subcontractor, the subcontractor may charge a maximum 10% fee. The General Contractor may charge a maximum of 5% in addition to subcontractor's fee.

14. BONDING

On bids exceeding \$ 100,000.00, submit with the Bid an Agreement to Bond for a 50% Performance Bond, and a 50% Labour & Material Payment Bond. Upon request, the successful Bidder will be required to provide the 50% Performance Bond and 50% Labour and Material Payment Bond from a bonding company acceptable to the Board. The cost of the bond is included in the bid sum, the amount of which is to be identified on the Bid Form.

15. EXAMINATION OF SITE & SITE VISIT

Location: St. Joseph Catholic School, 535 Birchbank Drive, Corunna, ON.

Date: Wednesday, March 13, 2019 at 11:00 am

Contact: Juan Galindo Cell: 226-402-4824 / Chris Palmer Cell: 519-818-6655

This is a MANDATORY SITE VISIT. Only contractors who attend the site visit will be permitted to submit a bid response. Attendance will be taken and form part of the Bid Documents

In submitting a bid, it will be assumed that the bidders have carefully examined the drawings and have included in the bid price the complete cost of the work contemplated by the drawings and specifications and other bid documents.

16. TIMING OF PROJECT

The schedule for the completion of the project is:

- Commencement no earlier than June 28, 2019.
- Completion no later than August 22, 2019.

17. PROJECT SPECIFIC REQUIREMENTS

Any and all damages to facilities while under the control of the contractor shall be repaired at the contractor's cost. Please be advised that the Owner has a No Smoking Requirement on the Owners' property. Contractors shall provide their own washroom facilities for their employees; board washrooms will be off limits to the contractor's employees. Contractors are requested to ensure that employees and suppliers are advised of these Requirements. Contractor shall remove rubbish and debris from the site on a daily basis or as directed by the Board. On completion of the work, all debris shall be removed; the floor shall be thoroughly cleaned and swept; the site shall be left in a tidy condition (construction clean). Do not use the Board's equipment or facilities for cleaning or for any reason.

18. INSURANCE

Contractor must maintain, at the Contractor's expense for the entire term of the Contract or as otherwise required. All insurance as set out below:

- The successful Contractor shall provide the Board with proof of insurance for Comprehensive General Liability and Property Damage with a limit of not less than **\$2,000,000.00 (two million dollars)** inclusive within seven (7) calendar days of the bid submission deadline.
- The successful Contractor shall provide the Board with proof of insurance for Motor Vehicle Public Liability and Property Insurance on all owned and rented equipment with a limit of not less than **\$2,000,000.00 (two million dollars)** inclusive within seven (7) calendar days of the bid submission deadline.
- The Contractor agrees to indemnify, hold harmless, and defend the Board from and against any and all liability for loss, damage and expense, which the Board may suffer or for which the Board may be held liable by reason of injury (including death) or damage to any property arising out of negligence on the party of the proponent or any of its representatives, employees, or subcontractors in the execution of the work performed or by way of ownership or operation of an automobile.
- The successful Contractor shall provide the Board with a complete certified copy of all policies. Copies of renewed policies must be provided to the Board on or before the policy renewal date for projects that extend past the original policy term or for multi-year contracts.
- The successful Contractor must name the St. Clair Catholic District School Board as additional insured on their insurance policies.

19. WORKPLACE SAFETY INSURANCE BOARD (WSIB)

Contractor must furnish a copy of Workplace Safety and Insurance Board Clearance Certificate of good standing, "Section 748" of the Workplace Safety and Insurance Act within seven (7) calendar days of the bid submission deadline.

20. PERMITS

The Board will apply and pay for a building permit if applicable. The contractor is to obtain all other permits as required to complete the project.

21. MEETINGS

A Post Bid Meeting may be convened and chaired by the Board who will invite Contractor and his major Subcontractors to review the Contract Documents and Bid submitted. This meeting will be prior to the

Board issuing a Letter of Intent or Contract. This meeting does not constitute or infer any contract award to the proposed contractor or any other contractor, nor that will the project proceed.

During the course of Work, scheduled progress meetings may be required at the call of the Project Leader.

22. GUARANTEE

The guarantee shall be for a period of 1 year from and after completion of the entire job and acceptance thereof by the Board unless a different period of time is specified with the Board's approval. The Contractor's guarantee shall cover all work under the Contract whether or not any portion or trade has been sublet.

The Contractor agrees to correct promptly, at the Contractor's own expense, defects or deficiencies in the Work which appear prior to and during the period of guarantee, or such longer periods as may be specified for certain products or work.

If the Contractor fails to make any replacements or repairs required hereunder, after notice from the Board and reasonable opportunity to do so, the Board may have such work done at Contractor's expense, including all necessary labour costs in connection therewith. Board shall inform Contractor in advance of the approximate cost of such work to be done by the Board.

23. SCHEDULE

The Contractor will be required to perform the work in accordance with the Schedule dates provided in 16. Timing of Project. Ordering of major and long delivery items shall begin immediately upon successful bidder's receipt of contract award. The Contractor will provide a construction schedule within five (5) days of being awarded the project.

Time is of the essence. Bidders are to include adequate manpower, overtime and shift work necessary to meet or improve the schedule, and to make up any time lost to weather or normal delays. Include travel, room and board costs for out of town workers, shop overtime and other premiums to expedite material and equipment, shipping premiums and any incentive costs required to meet the schedule.

24. CONTRACTED SERVICES PROGRAM

Contractors performing work on Board property must complete the Contracted Services Program. The Contracted Services Program is a joint program with Lambton Kent District School Board. This program has three basic components that **must** be met before the bid is awarded. Contractors who cannot meet the minimum requirements of this program will not be awarded this tender. Program information can be found on the Board's web site at www.st-clair.net or through the Board contact identified previously in this document. If the contractor has already been pre-qualified by LKDSB they must provide proof of completion. Identification badges can be used on SCCDSB or LKDSB property. All Insurance and WSIB certificates must be up to date under the Contracted Services Program.

25. HEALTH AND SAFETY

The Occupational Health and Safety Act describes the responsibilities of an employer. The Board requires Contractors to maintain procedures, training, and enforcement so that the responsibilities are carried out in the workplace. The Contractor shall abide by and strictly adhere to the regulations and conditions set out and laid down by the most current versions of the Occupational Health and Safety Act. All staff employed or hired by the Contractor and working on the Board's premise **MUST** be trained in WHMIS in

accordance with Occupational Health and Safety Act and Regulations. They MUST adhere to all of the Board's Health and Safety Procedures and Guidelines and to Municipal By-Laws.

Contractor will submit proof of its health and safety program, procedures and training as detailed above upon request by the Board.

The Contractor shall appoint a Competent Person as the Supervisor of this project. The Competent Person shall be as defined in Section 1 of the Occupational Health and Safety Act.

The successful Contractor shall conform to the Ontario "Occupational Health and Safety Act" and all regulations made under said act and assume full responsibility for contraventions of same.

All workplace injuries or accidents on Board property MUST be reported by the Contractor to the Board's representative within 24 hours.

Any workplace injury that is defined under the Occupational Health and Safety Act as a "Critical Injury" must be reported to the Board's representative IMMEDIATELY.

26. SAFE SCHOOL PROCEDURES

Contractor's staff is required to report to the main office of the site where work will be carried out during regular school hours and notify the school office staff of the purpose of the visit. The Contractor is required to adhere to all school specific procedures if applicable.

It is the responsibility of the Contractor's staff to sign in and sign out of the Log Book, which is located in the main office area, while performing their duties.

The following information must be recorded in a legible manner:

Date
Company Name
Employee Name
Employee Signature
Reason for Visit
Time Entering Building
Time Leaving Building

27. HOISTING, SCAFFOLDS, ELEVATED WORK PLATFORMS

The Contractor is responsible for all hoisting and other equipment necessary to facilitate their work.

28. TEMPORARY POWER

A source of electric power will be designated by the Board. The Board will allow a tie-in connection with fuse or breaker protection for the Contractor's estimated load requirements. The Contractor must provide the power connections and all extensions from the point to the job site. All electrical connections and extensions must meet ESA requirements and must be approved by the Board. The Contractor's estimated load requirements must not be exceeded without the Owner's permission.

29. NOISE AND TRAFFIC CONTROL

Bidders shall comply with all applicable **noise by-laws** (or local requirements governing same) and traffic routing that may be in effect during the life of the Project.

This **may** limit some activities to restricted time periods. Where the schedule requires for after hour work, the Contractor shall include all costs associated with obtaining the necessary permits to work such time periods.

The Contractor shall be responsible for all costs associated with providing a traffic officer as necessary to facilitate construction.

30. SITE ACCESS AND EGRESS

Contractors will be required to sign out a master key and will be assigned an access code for the alarm system. Successful Contractor will be responsible for building security during working hours and locking up the facility at night, which includes setting the alarm.

Any false alarms generated by the Contractor's workforce will result in a back charge for the costs incurred to the Board.

31. PARKING

Contractors must park within the designated areas and allow for provisions to and from the designated parking area onto the job site.

32. CONTRACTOR'S PERSONNEL

The Contractor shall, at its own expense, provide all the personnel required to take a proactive role in managing the project as it relates to their work and its coordination with other trades. This will include but is not limited to the following:

- Competent supervision of the work of the Contract and coordination with the work of other Subcontractors. This includes being responsible for and properly supervising any subcontractors of this subcontractor.
- All layout work required to complete the work of the trade contract.
- Competent supervision of the work of the trade contract to ensure work is done in accordance with the OHSA and any other applicable regulations.
- Expediting the procurement of material and equipment to ensure delivery by their required dates.
- Submission of Requests for Information where required in a timely manner and wherever possible providing the Board with information to assist in the answering of these requests.
- Submission in a timely manner of all required shop drawings and samples and assistance to the Board required to obtain approvals to suit the schedule. All shop drawings are to be reviewed by the Contractor prior to submitting for approval.
- Attendance at all construction coordination meetings when requested by the Board.
- Provision of all necessary information requested by the Board for cost control and billing purposes.
- Inspection of the work of the Trade Contract for defects and deficiencies and cooperation with the Board and other inspection authorities to allow their inspections to take place.
- Submission of pricing for all changes to the work within five (5) working days after receipt of change documentation including the breakdown and backup necessary to allow checking and approval.

33. ACCESSIBILITY FOR ONTARIANS WITH DISABILITIES ACT

The Purchaser is committed to the highest possible standards for accessibility. Proponent(s) must be capable to recommend and deliver, as appropriate for each Deliverable, accessible and inclusive Services consistent with the Ontario Human Rights Code (OHRC), the Ontarians with Disabilities Act, 2001 (ODA) and Accessibility for Ontarians with Disabilities Act, 2005 (AODA) and its regulations in order to achieve accessibility for Ontarians with disabilities.

In accordance with Ontario Regulation 429-07 made under the Accessibility for Ontarians with Disabilities Act, 2005 (Accessibility Standards for Customer Service), the Purchaser has established policies, practices and procedures governing the provision of its services to persons with disabilities.

Proponents are required to comply with the Purchaser's accessibility standards, policies, practices, and procedures, which may be in effect during the Term of the Agreement and which apply to the Deliverables to be provided by the Proponent.

34. CANADA'S ANTI-SPAM LEGISLATION

Please note that vendors are required to comply with all applicable laws, including CASL, in providing goods or services to the Board. This also extends to communications sent on the Boards behalf. The successful proponent(s) will be required to indemnify the Board for any failure by the successful proponent(s) to comply with CASL, to the extent that the successful proponent(s) action, or inaction, could expose the Board to liability.

35. WORKPLACE HAZARDOUS MATERIALS INFORMATION SYSTEM

The Proponent should provide Workplace Hazardous Materials Information System (WHMIS) material safety data sheets (MSDS) for all Services. Additionally, the Proponent should provide the Purchaser's personnel WHMIS training, as it relates to the Services, in accordance with the Ontario Occupational Health and Safety Act.

36. VENDOR PERFORMANCE

Where the Contractor fails to comply with any of its obligations under the Contract, the Board may issue a notice setting out the manner and time-frame for rectification. Within seven (7) Business Days of receipt of that notice or in a timeframe as otherwise agreed to, the Contractor shall either: (a) comply with that rectification notice; or (b) provide a rectification plan satisfactory to the Board. If the Contractor fails to either comply with that rectification notice or provide a satisfactory rectification plan, the Board may immediately terminate the Contract. Where the Contractor has been given a prior rectification notice, the same subsequent type of non-compliance by the Contractor may allow the Board to immediately terminate the Contract and result in the suspension of bidding privileges to the Board for up to two years at the sole unfettered discretion of the Board.

END OF INSTRUCTIONS TO BIDDERS

APPENDIX A: Agreement of Terms

I hereby acknowledge and agree that I have read and completed all Contract Terms and Conditions and Appendices.

I understand it is the SCCDSB's intention that this tender and the successful proponent(s)'s returned tender submission will form the basis of the proposed contract. All of the terms and conditions of this Tender must be accepted by the proponent(s) and incorporated into the proponent(s) Tender submission. It is the SCCDSB's intention to use a Purchase Order when establishing a contract with the successful proponent(s).

Acknowledgement of Addenda _____ through _____

This page must be signed below and returned with your submission for your tender to be accepted.

I/We the undersigned are duly authorized to execute this Bid Submission on behalf of:

NAME: _____

TITLE: _____

SIGNATURE: _____

COMPANY: _____

ADDRESS: _____

EMAIL: _____

TELEPHONE: _____

FAX: _____

Please refer to Appendix B: Bidder's Response Guide to ensure you include all necessary documentation with your bid submission

APPENDIX B: Bidder's Response Guide

Each bid submission should be structured using only the criteria identified in this bid document.

1. A signed copy of APPENDIX A: Agreement of Terms **must** be included for your bid submission to be accepted
2. A completed copy of APPENDIX B: Bid Form **must** be included in your bid submission.
3. Proof of WSIB Coverage and proof of insurance **must** be supplied before an award is made.
4. Bidders **must** provide one signed copy of the bid documents.
5. Supplemental material will not qualify as substitutes for direct responses to the bid's requirements, except for specifically requested material.
6. The successful contractor must be prequalified under the contracted services program before an award is made.
7. The work shall conform to the latest standards and codes listed in the Ontario School Code, National School Code, and all applicable provincial and municipal codes as of the date of this project in case of conflict or discrepancy; the most stringent requirement shall apply.
8. Provide inspection certificates as evidence that work conforms to requirements of Authority having jurisdiction.

ST. CLAIR CATHOLIC DISTRICT SCHOOL BOARD

ROOF REPLACEMENT

FOR

**ST. JOSEPH CATHOLIC SCHOOL
535 BIRCHBANK DRIVE
CORUNNA ONTARIO
N0N 1G0**

TENDER FORM

PROJECT No. 634-CP1914

FEBRUARY 2019

TENDER FORM

**Roof Replacement
for
St. Joseph Catholic School – Corunna
PROJECT No. 634-CP1914**

Name of Bidder _____
(Hereinafter Called the Tenderer Contractor)

Address _____

Being A _____ (A) which _____ (B)

Note: In space (A) above states type of company
Eg. "Incorporated", "limited", etc.
In space (B) above state "is" or "is not".

Registered under the laws of the Province of _____

DOES HEREBY AGREE TO:

1. Furnish all labour, materials, equipment, and service necessary for the completion of the **Roof Replacement** at **St. Clair Catholic District School Board** in accordance with Information of Tenderers, Form of Tender, General Conditions of Contract and Drawings by Remlap Building Services, 1407 Gore Road, RR1 Harrow, Ontario – N0R 1G0 for **TOTAL TENDER PRICE "A" (H.S.T. INCLUDED)**,

_____ \$ _____
(HST Included)

or such other sums as may be finally ascertained in accordance with the allowance for Roof Replacement and deductions as set out in the Tender Documents.

2. And also agrees that upon Tender acceptance to furnish a Performance and Maintenance Bond, Labour and Material Payment Bond and Liability Insurance as required by the Contract Documents, the cost of which is included in the Total Tender Price. The Tenderer hereby proposes:

Name of Bonding Company

Cost of Bonding

Stipulated prices shall include all labour, equipment and materials required to complete the work in every respect, including provincial sales tax.

TENDER FORM

**Roof Replacement
for
St. Joseph Catholic School – Corunna
PROJECT No. 634-CP1914**

Section “A”
Roof Replacement for St. Joseph Catholic School

The Bidder offers to provide all labour, materials and equipment services for the execution and completion of the work of the trade or trades herein and in accordance with the instructions for Bidders including Provincial Sales Tax for the stipulated sum of:

<u>Item</u> <u>No.</u>	<u>Description</u>	<u>Option No.1</u> <u>(HENRY)</u>	<u>Total</u> <u>Option No.2</u> <u>(SOPREMA)</u>	<u>Option No.3</u> <u>(IKO)</u>
A.	<u>ROOF AREAS D / E / F / G</u> The Roofing Contractor is to remove the existing Roof System completely to the metal deck with the exception to Roof Area 'G'. Then the Contractor is to supply and install Vapour Retarder, all Rigid Insulation, Protection board, etc. prior to installing a Two Ply Modified Bitumen Roof System as shown on the Enclosed Drawings and in accordance with the Project Specifications for this facility. <u>(The Contractor will include a Cash Allowance of \$15,000.00 with this price (if the allowance is not used, it will be taken off of the Total Tender Price).</u>	\$ _____	\$ _____	\$ _____
B.	<u>ROOF AREA 'C'</u> The Roofing Contractor is to remove the existing Roof System completely to the metal deck. Then the Contractor is to supply and install Vapour Retarder, all Rigid Insulation, Protection Board, etc. prior to installing a Two-Ply Modified Bitumen Roof System as shown on the Enclosed Drawings and in accordance with the Project Specifications for this facility. <u>(The Contractor will include a Cash Allowance of \$10,000.00 with this price (if the allowance is not used, it will be taken off of the Total Tender Price).</u>	\$ _____	\$ _____	\$ _____
C.	<u>ROOF AREA 'B' and 'A'</u> The Roofing Contractor is to remove the existing Roof System completely to the metal deck. Then the Contractor is to supply and install Vapour Retarder, all Rigid Insulation, Protection Board, etc. prior to installing a Two-Ply Modified Bitumen Roof System as shown on the Enclosed Drawings and in accordance with the Project Specifications for this facility. <u>(The Contractor will include a Cash Allowance of \$5,000.00 with this price (if the allowance is not used, it will be taken off of the Total Tender Price).</u>	\$ _____	\$ _____	\$ _____

TENDER FORM

**Roof Replacement
for
St. Joseph Catholic School – Corunna
PROJECT No. 634-CP1914**

Total Tender Price "A" (excluding HST)	\$ _____	\$ _____	\$ _____
Add 13% HST	\$ _____	\$ _____	\$ _____
Total Tender Price "A" (including HST)	\$ _____	\$ _____	\$ _____

Note: **ROOFING CONTRACTOR IS TO PROVIDE A PRICE (HOURLY RATE) TO CARRY OUT ANY ADDITIONAL WORK WHICH WOULD BE REQUIRED BY THE BOARD BEYOND THE SCOPE OF WORK.....** \$ _____
(Hourly Rate Excluding HST)

3. The Board will retain ten percent (10%) Holdback from each Invoice. In addition to the holdback the Board may withhold a sufficient and reasonable sum as determined by the Consultant until uncompleted work is finished or deficiencies in any part of the constructed works are rectified.

4. And agrees to leave this tender open for acceptance a minimum period of sixty (60) days from the tender closing date and not to modify, withdraw, or cancel their bid during this period.

The Tenderer also agrees that until the form of Agreement is completed and executed, this Tender, together with the acceptance thereof by the Owner and the Tenderer, shall remain open regardless of whether or not any other Tender has been previously accepted.

5. And also agrees to start the entire work no earlier than JUNE 28TH, 2019 after the Contract has been awarded to the successful bidder.

6. Documents and Acknowledgements

The Tenderer acknowledges that they have carefully examined the site of the proposed work, the existing premises and conditions; and thoroughly reviewed the Information to Tenderers, Tender Form, General Conditions, Supplementary General Conditions, Specifications, Drawings and the Addenda of the proposed Contract.

Addendum No. _____ **Date:** _____

Addendum No. _____ **Date:** _____

7. Completion of Work

We undertake to complete the work in _____ weeks after Receipt of Purchase Order or Written Authorization issued by **St. Clair Catholic School Board**

OR

To start work on _____ and to complete the work by _____

Completion date is not to exceed **AUGUST 22ND, 2019.**

TENDER FORM

**Roof Replacement
for
St. Joseph Catholic School – Corunna
PROJECT No. 634-CP1914**

8. Subcontractors

The Tenderer proposes to use the following Subcontractors, the portion of the work to be performed by each being as indicated with no more than one Subcontractor being proposed for any such portions. (If Subcontractors are not proposed, write N/A in the blank space.)

SUBCONTRACTOR

WORK OR TRADE

Signature of Authorized Officer: _____

Phone No. _____ Email: _____

Name of Signature: _____

Witness: _____

Dated At: _____

This _____ day of _____ 2019.

NOTES:

- If this Tender is submitted by or on behalf of any Corporation by some duly authorized officer, or agent thereof, who shall subscribe their name and office, the Seal of the Corporation shall be affixed.***
- The Owner reserves the right to accept or reject any part OR all of bid and may not necessarily award the tender to the lowest bidder.***

**SPECIFICATION
ON
ROOF REPLACEMENT**

FOR

ST. CLAIR CATHOLIC DISTRICT SCHOOL BOARD

AT

**ST. JOSEPH CATHOLIC SCHOOL
535 BIRCHBANK DRIVE
CORUNNA ONTARIO
N0N 1G0**

PROJECT No. 634-CP1914

FEBRUARY 2019

3.0 GENERAL

**Roof Replacement
for
St. Joseph Catholic School – Corunna
PROJECT No. 634-CP1914**

3.1 Warranties

3.1.1 Roofing Application Guarantee

Warrant the work of this section including insulation, membrane and sheet metal work against defects and any actual leakage in accordance with the General Conditions but for a period of two (2) years and agree to make good promptly any defects which occur or become apparent within the warranty period, such defects to include but not be restricted to leaking, blistering, lifting, curling, wrinkling, alligating, fish mouths, loosening and splitting of seams, buckling of counter flashing, improper securement of flashings, improper use or application of materials.

3.1.2 Membrane System Warranty:

Provide a Written Membrane System Warranty to **St. Clair Catholic District School Board – Roof Replacement** stating that the Roofing Membrane Manufacturer will pay the entire cost to have the Authorized Roofing Applicator search any leaks which occur due to Membrane or Application (workmanship) failure within the warranty period of fifteen years.

4.0 PRODUCTS

**Roof Replacement
for
St. Joseph Catholic School – Corunna
PROJECT No. 634-CP1914**

OPTION NO. 1 – HENRY COMPANY

4.1 Modified Bitumen Membrane

- 4.1.1 Modified Bitumen Sheets shall conform to CGSB 37-GP-56M “Membrane, Modified, Bituminous, Prefabricated and Reinforced for Roofing”; Type 2, Class C, Grade 2 for Base Sheets and Type 1, Class A, Grade 2 for Cap Sheets.
- 4.1.2 The Contractor may bid on any Manufacturer’s Systems specified for torching application of the base sheet and torching of the cap sheet for this roof area. The colour of the granular surface is to be selected by the Owner. Supply additional granules to be applied to bitumen outflows between membrane sheets.
- 4.1.3 Modified Bitumen Membrane Two-Ply System shall be as specified or approved equal and accepted by the Consultant and Owner.
- a) Henry Company**
- i) Base Sheet (NP180P/S) and (NP180 S/P 3.5 Cap Sheet)
 - ii) Self-Adhesive Membrane (NP 180 Tack Sheet)
 - iii) Cap Sheet (NP250gT4)

4.2 Vapour Retarder

- 4.2.1 Vapor-Bloc SA is a Self-Adhered Vapour Barrier Membrane consisting of an SBS rubberized asphalt compound which is integrally laminated to a blue cross-laminated polyethelene film.

4.3 Primer

- 4.3.1 As required by each Roof Membrane Manufacturer.

4.4 Rigid Insulation

- 4.4.1 Insulation shall be roof insulation which is rigid closed cell, Polyiso Foam Insulation, integrally laminated to fiber-reinforced paper facers, thermal resistance of insulation shall be R-23.6 (L.T.T.R.) (4.0 inch) for the main roof area and R-11.4 (L.T.T.R.) (4 inch) around recessed roof drains, Resistance R-Value in accordance with ASTM C1289-11A. All insulation boards shall be 4 feet by 4 feet in size. **ONLY ROOF AREA ‘G’, the rigid insulation shall be R-11.4 (L.T.T.R.) (2.0 inch) for the main roof area.**

4.5 Insulation Overlay Boards

- 4.5.1 Bituminous Boards consisting of multi-ply, semi-rigid Asphaltic Roofing Substrate Board composed of a mineral fortified Asphaltic core formed between two Asphaltic saturated fiberglass liners. Length 1200mm x Width 1500mm x thickness 4.5 mm such as Recover Board by Bakor or approved equal by the Consultant.

4.6 Bitumen Adhesive

- 4.6.1 Royal Millennium One-Step Foamable Adhesive to be used for application of thermal barrier (if required) along with rigid insulation and overlay boards.

4.0 PRODUCTS

**Roof Replacement
for
St. Joseph Catholic School – Corunna
PROJECT No. 634-CP1914**

OPTION NO. 1 – HENRY COMPANY

4.7 Vent Pipe Stack Flange

- 4.7.1 The vent pipe stack flange shall be Thaler Roofing Specialties Products Inc. Model No. SJ-37 insulated flange. The Roofing Contractor shall verify the inside diameter of the vent pipe stack for each location.

4.8 Hot Exhaust Stack Flashings

- 4.8.1 The hot pipe flashings shall be Thaler Roofing Specialties Products Inc. Model No MEF-3A aluminum flashings with split collar to suit new roof system. The Contractor shall fill Roxul Insulation between pipe and flange.

4.9 Roof Drain

- 4.9.1 Roof Drain shall be Thaler Roof Specialties Products Inc. Model No. RD-4-RR with FURCO FOR DIRECT CONNECT. Outlet size shall be verified on site by the Roofing Contractor.

4.10 Tapered Insulation (Recessed Roof Drains)

- 4.10.1 The tapered insulation shall be faced Isocyanurate Boards conforming to CAN/CGSB-51.26-M86,
4.11.1 The tapered insulation shall be faced Isocyanurate Boards conforming to CAN/CGSB-51.26-M86, meeting the requirements of ULC S126 Polyisocyanurate foam panels chemically bonded during the foaming process to facers on the top and bottom organic surfaces. Tapered panels shall not be less than 13m at any point of the roof to the slope indicated on the Roof Plan and Details.

4.11 Elastomeric Modified Bitumen Adhesive

- 4.11.1 Bakor MBA Gold is a fib rated rubberized adhesive with a bonding strength designed for adhering SBS modified bitumen and asphalt coated membranes directly to properly prepared substrates.

4.12 Metal Flashings

- 4.12.1 Metal flashings shall be 24ga. Colorite 8000 Series pre-finished steel (both sides) as manufactured by Westeel Roscoe, Steelcolour 8000 Series or Owner approved equal, formed to comply with field conditions. The colour is to be selected by the Owner from the Manufacturer's standard colours. A one meter "test bend" for each general metal flashing condition shall be completed and presented to the Owner's Representative for approval prior to general fabrication.

4.13 Sealants

- 4.13.1 Caulking Sealants for metal flashing shall be one-part silicone to conform to CGSB 19 GP 96. Sealants shall be manufactured by Canadian General Electric, Dow Corning or approved equal. The colour of the sealant shall be identical to the colour of the metal flashing; the Owner is to approve the colour before ordering the sealant. This sealant shall be applied to all metal flashing joints including the reglet.

4.0 PRODUCTS

**Roof Replacement
for
St. Joseph Catholic School – Corunna
PROJECT No. 634-CP1914**

OPTION NO. 1 – HENRY COMPANY

4.14 Roofing Gravel

- 4.14.1 The gravel shall be ¼” to 5/8” size; water washed pea gravel, well graded, opaque, non-porous material free of fines, moisture, ice, and snow or long splinters and conforms to ASTM D1863-086.

4.15 Framing Lumber

- 4.15.1 Framing Lumber on top of roof area shall be pressure treated for rot resistance conforming to CSA 0322-1976 and CSA 080-M1983; sizes shown on the Drawings. Grade SPF No. 2 or better.

4.16 Plywood

- 4.16.1 Exterior Grade “fir” to CSA 0121 or CSA 0151, ½” and ¾” thick, as detailed on Enclosed Drawings.

4.17 Rough Hardware and Nails

- 4.17.1 The Roofing Contractor shall supply all rough hardware where required. Nails, spikes, screws, bolts, etc. shall be of sufficient size and type to rigidly secure all members into place. All nails shall be hot dip galvanized.

4.18 Painting

- 4.18.1 All existing gas lines, exhaust fan hoods and roof top units shall be cleaned and scraped prior to being repainted.
- 4.18.2 Clean and prime with Alkyd Metal Primer before applying two coats of enamel paint. The colour shall be selected by the Owner.

4.19 Plastic Roof Cement

- 4.19.1 Pro-Grade Plastomers 810-21 Plastic Cement is composed of asphalt synthetic rubber, fiber and fillers exceeding the requirements of CAN/CGSB-37.5. This product is manufactured by Bakor or approved equal.

4.20 Precast Pads

- 4.20.1 Precast concrete pads shall be 24 inches by 24 inches by 2-inch-thick for additional walkway, etc. as shown on Roof Plan. Pads shall be placed on a 20 inch by 20 inches by 2-inch-thick sections of rigid Type 4 extruded polystyrene insulation. **(45 new pavers in total)**

4.21 Exhaust Vent Flashings

- 4.21.1 Thaler EVF Exhaust Vent Flashings consist of a double wall metal flashing sleeve with integral deck flange, matching removable hood (screw fastened), pre-molded urethane insulation lines and EPDM Base Seal.

5.0 EXECUTION

**Roof Replacement
for
St. Joseph Catholic School – Corunna
PROJECT No. 634-CP1914**

OPTION NO. 1 – HENRY COMPANY

5.1 TEAR-OFF

- 5.1.1 Prior to the start of installation, the roofing Contractor shall examine all roof areas included in this Specification. The Roofing Contractor shall notify the Consultant of any unacceptable conditions.
- 5.1.2 These conditions include, but are not limited to, uneven deck surfaces, improperly installed curbs and nailers, surfaces with fins or sharp projections, and surfaces contaminated with incompatible materials. Work shall not begin until these conditions have been corrected. Protect membrane in high traffic areas, work by other trades, application of gravel, etc.
- 5.1.3 Completely remove the existing **Built-Up Roof System** completely to the existing metal deck with the exception to Roof Area 'G' where the existing Two-Ply Modified Bitumen Roof Membrane along with ½ inch fiberboard rigid insulation on top the existing Polyiso Rigid Insulation is to be removed only. Only tear-off those roofing components that can be re-roofed in the same day. Tear-off work shall not be left exposed at the end of the work day.

5.2 INSTALLATION – Two Ply Modified Bitumen Membrane Roof System

- 5.2.1 The areas to be re-roofed must have all the roofing components removed completely to the metal roof dish before applying the new roof system. Install all carpentry items such as curb extensions, wood blocking at roof perimeters, etc. as detailed on the Drawings. All wood members which are to be anchored to masonry construction shall be permanently fastened into place. Do not use fasteners which will cause spalling, cracking or deformation of fastened materials.
- 5.2.2 Apply roofing materials over clean and dry surfaces in accordance with the Manufacturer's Recommendations. The re-roofing operations shall be performed on a continuous basis as weather conditions allow.
- 5.2.3 Install all new wood blocking and plywood as detailed on the applicable details
- 5.2.4 **Installation of Vapour Retarder**
 - .1 Apply Blueskin Primer by roller or spray to all surfaces as required and allow drying.
 - .2 The deck surface must be clean and sound, free of loose materials or contaminants such as water and grease which may compromise the performance of this product.
 - .3 Unroll and align air/vapour barrier centered at low point of roof or drain. Apply air/vapour removing release paper providing 2-inch side and end laps. Seal around projections as per manufacturer's recommendations.
 - .4 Apply self-adhesive membrane without any wrinkles or fish mouths.
 - .5 The vapour retarder is to be carried up the vertical surfaces a minimum of 8 inches above roof deck.

5.0 EXECUTION

Roof Replacement for St. Joseph Catholic School – Corunna PROJECT No. 634-CP1914

OPTION NO. 1 – HENRY COMPANY

5.2.5 Installation of Rigid Insulation Boards

- .1 Install boards with low-rise foam adhesive to the vapour retarder. On all insulation surfaces intended for board coverage apply beads of 20mm (3/4") wide on 200mm (8") centers.
- .2 Firmly set the rigid insulation boards in staggered fashion. All boards must be butted tightly together.
- .3 Apply only as many boards as can be covered in the same day.

5.2.6 Installation of Insulation Overlay Boards

- .1 Install boards with low-rise foam adhesive to the rigid insulation as indicated. On all insulation surfaces intended for board coverage, apply beads of 20mm (3/4") wide on 200mm (8") centers.
- .2 Firmly set the insulation overlay boards, long joints continuously and short joints staggered. All boards must be evenly and tightly butted together.
- .3 All joints between boards and insulation will be staggered.
- .4 Apply only as many boards as can be covered in the same day.

5.2.7 Base Sheet Installation

- .1 Install the base sheet roof membrane starting from the low point (roof drain) to the high point. The base sheet is to be adhered with adhesive to the overlay boards to the parapet wall.
- .2 Unroll base sheet flashing at drain level with first side lap lined-up with drain center.
- .3 Overlap side laps by 75mm along lines provided to this end and overlap end laps by 150mm. Stagger end joints by at least 300mm.
- .4 Re-Roll base sheet and unroll again onto bed of cold adhesive with a notched squeegee having notches 6mm (1/4") wide 3mm (1/8") deep and spaced 25mm (1") on centers. The side and end lap must be HEAT WELDED (FUSED) TOGETHER WITH A LEISTER HAND HELD GUN OR APPROVED TO EQUAL TO ENSURE GOOD FUSION. Also avoid the cold adhesive from within two inches of the side and end laps.
- .5 Avoid forming wrinkles, air pockets or fish-mouthing. The modified bitumen membrane should be cut in maximum lengths of 55mm (18 ft) and allowed to relax on the jobsite.
- .6 This membrane is to be carried up to the inside face of parapet wall prior to installing new plywood on inside face of parapet wall.

5.2.8 Installation of Additional Plywood and/or Wood Blocking

- .1 Install all new wood blocking and plywood as detailed on the applicable Details.

Note: The new plywood detail on the inside face of parapet wall is not to be installed until the first ply of base sheet roof membrane is applied 3 inches up the vertical surface of parapet wall.

5.0 EXECUTION

Roof Replacement for St. Joseph Catholic School – Corunna PROJECT No. 634-CP1914

OPTION NO. 1 – HENRY COMPANY

5.2.9 Base Sheet Flashing Installation

- .1 Apply base sheet flashing only once primer coat is dry.
- .2 Install base sheet flashing in one (1) metre widths to cover roofing substrate over 100mm. Overlap side laps by 75mm. Stagger side laps by a least 100mm from base sheet overlaps on the roof to avoid excessive layering.
- .3 Apply base sheet flashing directly onto substrate by removing silicone paper cover sheet. Proceed from top to bottom. Once in place, apply pressure manually in a uniformed fashion to obtain homogenous adherence over the entire surface. Preferably seal seams with aluminum applicator and rubber roller. The flashing membrane is to be adhered to the bottom of the wood blocking on the outside face of parapet wall. Nail outside edge at 300mm O.C. Burn off plastic film of base sheet membrane before adhering base sheet flashing over it.
- .4 Avoid forming wrinkles, air pockets or fish-mouths.

Note: ALL BASE SHEET FLASHING MEMBRANE IS TO BE EXTENDED TO THE BOTTOM OF WOOD FASCIA.

5.2.10 Cap Sheet Installation

- .1 Prior to installing the cap sheet membrane, all insulated flanges are to be installed around each roof penetration and secured to the metal roof deck with four (4) fasteners per flange before applying base sheet target section on top.
- .2 Once the base sheet has been applied, the stripping has been completed and no indications of defects are present, then the cap sheet shall be laid.
- .3 Begin application of the cap sheet at the lowest edge. Cap sheet shall be unrolled and care be taken to ensure proper alignment of the first roll.
- .4 Cap sheet shall be torched into place in accordance with the Recommendations of the Membrane Manufacturer, to the base sheet membrane.
- .5 The seams between the base sheet and cap sheet shall be staggered a minimum of 300 mm (12 inches).
- .6 Care should be taken to ensure heating is consistent across the width in order to avoid skips or voids. Bitumen should flow out from the lap 6mm (1/4") to ensure a tight seal.
- .7 All lap seams on the cap sheet are to be checked after membrane installation.

5.2.11 Cap Sheet Flashing Installation

- .1 Cap sheet membrane installation shall be laid in strips 1m wide along the parapet. Side laps shall be a minimum of 100mm (4 inches) overlap.
- .2 Extend cap sheet a minimum of 150mm (6 inches) onto roof surface from the intersection of roof and vertical surfaces and extend to the top of the parapet wall to the outside of wall.

5.0 EXECUTION

**Roof Replacement
for
St. Joseph Catholic School – Corunna
PROJECT No. 634-CP1914**

OPTION NO. 1 – HENRY COMPANY

- .3 The flashing membrane shall be anchored to the wood nailers by nailing through discs or using nails with 25mm (1 inch) minimum diameter head semi-solidly attached. Nail a minimum of 200mm (8 inches) on center.
- .4 Matching granules shall be used to cover excess between flow at seams.

5.2.12 **Flood Coat and Gravel Cover**

- .1 Apply a flood coat of cold roofing adhesive (MBA Gold) at the rate of 6.5 gallons/100ft² as recommended by Manufacturer (Bakor).
- .2 Then embed new approved pea stone gravel at 20 kg/m² (450 lbs/100ft²) while adhesive is still wet.

5.2.13 **Concrete Pavers**

- .1 Install concrete pavers as indicated on the Roof Plan on top of one inch extruded polystyrene rigid insulation (Type 4).

5.3 INSTALLATION – Metal Flashings

- 5.3.1 Cap and counter flashings shall be jointed with a double S-type locked joint. Flashings shall be installed with continuous clips secured to wood capping blocking at 12 inches O.C.
- 5.3.2 Flashing shall be fabricated to shapes on site with all necessary breaks for adequate expansion.
- 5.3.3 The inside face of the metal cap flashing between the S-locked joints is to be secured with three (3) fasteners matching the colour of the metal cap with a neoprene washer between the fastener head and inside face of the metal cap flashing.
- 5.3.4 All joints shall be sealed with approved sealant.
- 5.3.5 Counter flashings shall be installed at all reglets and curbs with at least three (3) inches below the top of roof curb or reglet.

5.4 CLEAN-UP

- 5.4.1 Upon completion of the installation, the work shall be left clean and free of defects which might affect the durability or appearance of the building. Clean all roof surfaces, including adjacent roofs and grounds of all foreign matter resulting from this Roofing Project.

6.0 PRODUCTS

**Roof Replacement
for
St. Joseph Catholic School – Corunna
PROJECT No. 634-CP1914**

OPTION NO. 2 – SOPREMA

6.1 Modified Bitumen Membrane

- 6.1.1 Modified Bitumen Sheets shall conform to CGSB 37-GP-56M “Membrane, Modified, Bituminous, Prefabricated and Reinforced for Roofing”; Type 2, Class C, Grade 2 for Base Sheets and Type 1, Class A, Grade 2 for Cap Sheets.
- 6.1.2 The Contractor may bid on any Manufacturer’s Systems specified for torching application of the base sheet and torching of the cap sheet for this roof area. The colour of the granular surface is to be selected by the Owner. Supply additional granules to be applied to bitumen outflows between membrane sheets.
- 6.1.3 Modified Bitumen Membrane Two-Ply System shall be as specified or approved equal and accepted by the Consultant and Owner.
- a) Soprema**
- i) Base Sheet (SOPRALENE 180 S/P 3.5 for Cap Sheet)
 - ii) Self-Adhesive Membrane (NP 180 Tack Sheet)
 - iii) Cap Sheet (NP250gT4) for flashing membrane.

6.2 Vapour Retarder

- 6.2.1 Soprapap'R is a self-adhesive membrane composed of SBS modified bitumen and a tri-laminated woven polyethylene facer. The under face is covered with a silicone release film.

6.3 Insulation Soprasmart Board 180

- 6.3.1 Soprasmart board 180 is a high-performance high-density support panel composed of SBS modified bitumen membrane with a non-woven polyester reinforcement, factory-laminated on asphaltic board (SOPRABOARD). The surface is covered with a thermo-fusible plastic film.

6.4 Primer

- 6.4.1 The primer shall consist of Elastocol Stick designed for use with self-adhered SBS modified bitumen base sheet flashing membrane. The risk of primer flare-up is eliminated when modified bitumen cap sheets are thermo-fused to the self-adhered base sheet flashing membranes.

6.5 Duotack

- 6.5.1 Duotack is a LOW-RISE two-part urethane adhesive to be used for the application of rigid insulation.

6.6 Vent Pipe Stack Flange

- 6.6.1 The vent pipe stack flange shall be Thaler Roofing Specialties Products Inc. Model No. SJ-37 insulated flange. The Roofing Contractor shall verify the inside diameter of the vent pipe stack for each location.

6.0 PRODUCTS

Roof Replacement
for
St. Joseph Catholic School – Corunna
PROJECT No. 634-CP1914

OPTION NO. 2 – SOPREMA

6.7 Hot Exhaust Stack Flashings

- 6.7.1 The hot pipe flashings shall be Thaler Roofing Specialties Products Inc. Model № MEF-3A aluminum flashings with split collar to suit the new Two-Ply Modified Bitumen Roof System. The Roofing Contractor shall verify the inside diameter of the hot pipe stack for each location and fill between the flange and pipe with ROXUL Insulation.

6.8 Roof Drain

- 6.8.1 Roof Drain shall be Thaler Roof Specialties Products Inc. Model No. RD-4-RR with FURCO FOR DIRECT CONNECT. Outlet size shall be verified on site by the Roofing Contractor.

6.9 Rigid Insulation

- 6.9.1 Insulation shall be roof insulation which is rigid closed cell, Polyiso Foam Insulation, integrally laminated to fiber-reinforced paper facers, thermal resistance of insulation shall be R-23.6 (L.T.T.R.) (4.0 inch) for the main roof area and R-11.4 (L.T.T.R.) (2.0 inch) around recessed roof drains, Resistance R-Value in accordance with ASTM C1289-11A. All insulation boards shall be 4 feet by 4 feet in size. **ONLY ROOF AREA 'G', the rigid insulation shall be R-11.4 (L.T.T.R.) (2.0 inch) for the main roof area.**

6.10 Tapered Insulation (Recessed Roof Drains)

- 6.10.1 The tapered insulation shall be faced Isocyanurate Boards conforming to CAN/CGSB-51.26-M86, meeting the requirements of ULC S126 Polyisocyanurate foam panels chemically bonded during the foaming process to facers on the top and bottom organic surfaces. Tapered panels shall not be less than 13m at any point of the roof to the slope indicated on the Roof Plan and Details.

6.11 Elastomeric Modified Bitumen Adhesive

- 6.11.1 COLPLY EF is a low volatile organic compound (VOC), low odour, 100% solids and solvent-free polyether-based adhesive.

6.12 Metal Flashings

- 6.12.1 Metal flashings shall be 24ga. **Colorite 8000 Series** pre-finished steel (both sides) as manufactured by Westeel Roscoe, **Steelcolour 8000 Series** or Owner approved equal, formed to comply with field conditions. The colour is to be selected by the Owner from the Manufacturer's standard colours. A one meter "test bend" for each general metal flashing condition shall be completed and presented to the Owner's Representative for approval prior to general fabrication.

6.13 Sealants

- 6.13.1 Caulking Sealants for metal flashing shall be one-part silicone to conform to CGSB 19 GP 96. Sealants shall be manufactured by Canadian General Electric, Dow Corning or approved equal. The colour of the sealant shall be identical to the colour of the metal flashing; the Owner is to approve the colour before ordering the sealant. This sealant shall be applied to all metal flashing joints including the reglet.

6.0 PRODUCTS

**Roof Replacement
for
St. Joseph Catholic School – Corunna
PROJECT No. 634-CP1914**

OPTION NO. 2 – SOPREMA

6.14 Roofing Gravel

- 6.14.1 The gravel shall be ¼” to 5/8” size; water washed pea gravel, well graded, opaque, non-porous material free of fines, moisture, ice, and snow or long splinters and conforms to ASTM D1863-086.

6.15 Framing Lumber

- 6.15.1 Framing Lumber on top of roof area shall be pressure treated for rot resistance conforming to CSA 0322-1976 and CSA 080-M1983; sizes shown on the Drawings. Grade SPF No. 2 or better.

6.16 Plywood

- 6.16.1 Exterior Grade “fir” to CSA 0121 or CSA 0151, ½” and ¾” thick, as detailed on Enclosed Drawings.

6.17 Rough Hardware and Nails

- 6.17.1 The Roofing Contractor shall supply all rough hardware where required. Nails, spikes, screws, bolts, etc. shall be of sufficient size and type to rigidly secure all members into place. All nails shall be hot dip galvanized.

6.18 Painting

- 6.18.1 All existing gas lines, exhaust fan hoods and roof top units shall be cleaned and scraped prior to being repainted.
- 6.18.2 Clean and prime with Alkyd Metal Primer before applying two coats of enamel paint. The colour shall be selected by the Owner.

6.19 Plastic Roof Cement

- 6.19.1 Pro-Grade Plastomers 810-21 Plastic Cement is composed of asphalt synthetic rubber, fiber and fillers exceeding the requirements of CAN/CGSB-37.5. This product is manufactured by Bakor or approved equal.

6.20 Precast Pads

- 6.20.1 Precast concrete pads shall be 24 inches by 24 inches by 2-inch-thick for additional walkway, etc. as shown on Roof Plan. Pads shall be placed on a 20 inch by 20 inches by 2-inch-thick sections of rigid Type 4 extruded polystyrene insulation. **(45 new pavers in total)**

6.21 Exhaust Vent Flashings

- 6.21.1 Thaler EVF Exhaust Vent Flashings consist of a double wall metal flashing sleeve with integral deck flange matching removable hood (screw fastened) pre-molded urethane) insulation lines and EPDM base seal.

7.0 EXECUTION

Roof Replacement for St. Joseph Catholic School – Corunna PROJECT No. 634-CP1914

OPTION NO. 2 – SOPREMA

7.1 Tear-Off

- 7.1.1 Prior to the start of installation, the roofing Contractor shall examine all roof areas included in this Specification. The Roofing Contractor shall notify the Consultant of any unacceptable conditions.
- 7.1.2 These conditions include, but are not limited to, uneven deck surfaces, improperly installed curbs and nailers, surfaces with fins or sharp projections, and surfaces contaminated with incompatible materials. Work shall not begin until these conditions have been corrected. Protect membrane in high traffic areas, work by other trades, application of gravel, etc.
- 7.1.3 Completely remove the existing **Built-Up Roof System** completely to the existing metal deck with the exception to Roof Area 'G' where the existing Two-Ply Modified Bitumen Roof Membrane along with ½ inch fiberboard rigid insulation on top the existing Polyiso Rigid Insulation is to be removed only. Only tear-off those roofing components that can be re-roofed in the same day. Tear-off work shall not be left exposed at the end of the work day.

7.2 INSTALLATION – Two Ply Modified Bitumen Membrane Roof System

- 7.2.1 The areas to be re-roofed must have all the roofing components removed completely to the metal roof deck before applying the new roof system. Install all carpentry items such as curb extensions, wood blocking at roof perimeters, etc. as detailed on the Drawings. All wood members which are to be anchored to masonry construction shall be permanently fastened into place. Do not use fasteners which will cause spalling, cracking or deformation of fastened materials.
- 7.2.2 Apply roofing materials over clean and dry surfaces in accordance with the Manufacturer's Recommendations. The re-roofing operations shall be performed on a continuous basis as weather conditions allow.
- 7.2.3 Install all new wood blocking and plywood as detailed on the applicable details.
- 7.2.4 **Installation of Vapour Retarder**
 - .1 When applying Soprapap'R over top metal deck, the existing surface is not required to be primed.
 - .2 The deck surface must be clean and sound, free of loose materials or contaminants such as water and grease which may compromise the performance of this product.
 - .3 Unroll and align air/vapour barrier centered at low point of roof or drain. Apply air/vapour removing release film providing 3-inch side laps and 6-inch end last (minimum). Seal around projections as per manufacturer's recommendations.
 - .4 Apply self-adhesive membrane without any wrinkles or fish mouths.
 - .5 The vapour retarder is to be carried up the vertical surfaces a minimum of 8 inches above roof deck.
- 7.2.5 **Installation of Rigid Insulation Boards**
 - .1 Install boards with Duotack Adhesive to the vapour retarder. On all insulation surfaces intended for board coverage apply beads of 20mm (3/4") wide on 200mm (8") centers.
 - .2 Firmly set the rigid insulation boards in staggered fashion. All boards must be butted tightly together.
 - .3 Apply only as many boards as can be covered in the same day.

7.0 EXECUTION

Roof Replacement for St. Joseph Catholic School – Corunna PROJECT No. 634-CP1914

OPTION NO. 2 – SOPREMA

7.2.6 Installation of Soprasmart Board

- .1 Install Smart Boards with Duotack Adhesive to the rigid insulation as indicated. On all insulation surfaces intended for board coverage, apply continuous strips of 13 to 19 mm (½ to ¾ inch) on 150 mm (6") centers for eight (8) feet around roof perimeter and 200 mm (8") centers for the field of the roof.
- .2 Firmly set the Smart Boards, into the strips of Duotack Adhesive. All boards must be evenly and tightly butted together in soldier fashion.
- .3 Apply only as many boards as can be covered in the same day.
- .4 Install Sopralap cover strips across the end laps on the panels by heat-welded with a propane torch.

7.2.7 Installation of Additional Plywood and/or Wood Blocking

Install all new wood blocking and plywood as detailed on the applicable Details.

Note: The new plywood detailed on the inside face of parapet wall is not to be installed until the first ply of base sheet roof membrane is applied 3 inches up the vertical surface of parapet wall.

7.2.8 Application of Primer

- .1 Apply primer to the wood blocking and plywood surfaces which will be in contact with the self-adhesive membranes at a rate of 0.2 to 0.3 l/m². All surfaces to be primed must be free of rust, dust or any residue that may hinder adherence. Cover primed surfaces with roofing membrane as directed by the Manufacturer.

7.2.9 Base Sheet Flashing Installation

- .1 Apply base sheet flashing only once primer coat is dry.
- .2 Install base sheet flashing in one (1) metre widths to cover roofing substrate over 100mm. Overlap side laps by 75mm. Stagger side laps by a least 100mm from base sheet overlaps on the roof to avoid excessive layering.
- .3 Apply base sheet flashing directly onto substrate by removing silicone paper cover sheet. Proceed from top to bottom. Once in place, apply pressure manually in a uniformed fashion to obtain homogenous adherence over the entire surface. Preferably seal seams with aluminum applicator and rubber roller. The flashing membrane is to be adhered 4 inches over top of the Blueskin membrane on the outside face of parapet wall. Nail outside edge at 300mm O.C. Burn off plastic film of base sheet membrane before adhering base sheet flashing over it.
- .4 Avoid forming wrinkles, air pockets or fish-mouths.

Note: ALL BASE SHEET FLASHING MEMBRANES ARE TO BE EXTENDED TO THE BOTTOM OF WOOD FASCIA.

7.0 EXECUTION

Roof Replacement for St. Joseph Catholic School – Corunna PROJECT No. 634-CP1914

OPTION NO. 2 – SOPREMA

7.2.10 Cap Sheet Installation

- .1 Prior to installing the cap sheet membrane, all insulated flanges are to be installed around each roof penetration and secured to the metal roof deck with four (4) fasteners per flange before applying base sheet target section on top.
- .2 Once the base sheet has been applied, the stripping has been completed and no indications of defects are present, then the cap sheet shall be laid.
- .3 Begin application of the cap sheet at the lowest edge. Cap sheet shall be unrolled and care be taken to ensure proper alignment of the first roll.
- .4 Cap sheet shall be torched into place in accordance with the Recommendations of the Membrane Manufacturer, to the base sheet membrane.
- .5 The seams between the base sheet and cap sheet shall be staggered a minimum of 300 mm (12 inches).
- .6 Care should be taken to ensure heating is consistent across the width in order to avoid skips or voids. Bitumen should flow out from the lap 6mm (1/4") to ensure a tight seal.
- .7 All lap seams on the cap sheet are to be checked after membrane installation.

7.2.11 Cap Sheet Flashing Installation

- .1 Cap sheet membrane installation shall be laid in strips 1m wide along the parapet. Side laps shall be a minimum of 100mm (4 inches) overlap.
- .2 Extend cap sheet a minimum of 150mm (6 inches) onto roof surface from the intersection of roof and vertical surfaces and extend to the top of the parapet wall to the outside of wall.
- .3 The flashing membrane shall be anchored to the wood nailers by nailing through discs or using nails with 25mm (1 inch) minimum diameter head semi-solidly attached. Nail a minimum of 200mm (8 inches) on center.
- .4 Matching granules shall be used to cover excess between flow at seams.

7.2.12 Flood Coat and Gravel Cover

- .1 Apply a flood coat of cold roofing adhesive (COLPLY EF) at the rate of 5 gallons/100ft² as recommended by Manufacturer (Soprema).
- .2 Then embed new approved pea stone gravel at 20 kg/m² (450 lbs/100ft²) while adhesive is still wet.

7.2.13 Concrete Pavers

- .1 Install concrete pavers as indicated on the Roof Plan on top of one-inch extruded polystyrene rigid insulation (Type 4).

7.0 EXECUTION

**Roof Replacement
for
St. Joseph Catholic School – Corunna
PROJECT No. 634-CP1914**

OPTION NO. 2 – SOPREMA

7.3 INSTALLATION – Metal Flashings

- 7.3.1 Cap and counter flashings shall be jointed with a double S-type locked joint. Flashings shall be installed with continuous clips secured to wood capping blocking at 12 inches O.C.
- 7.3.2 Flashing shall be fabricated to shapes on site with all necessary breaks for adequate expansion.
- 7.3.3 The inside face of the metal cap flashing between the S-locked joints is to be secured with three (3) fasteners matching the colour of the metal cap with a neoprene washer between the fastener head and inside face of the metal cap flashing.
- 7.3.4 All joints shall be sealed with approved sealant.
- 7.3.5 Counter flashings shall be installed at all reglets and curbs with at least three (3) inches below the top of roof curb or reglet.

7.4 CLEAN-UP

- 7.4.1 Upon completion of the installation, the work shall be left clean and free of defects which might affect the durability or appearance of the building. Clean all roof surfaces, including adjacent roofs and grounds of all foreign matter resulting from this Roofing Project.

8.0 PRODUCTS

**Roof Replacement
for
St. Joseph Catholic School – Corunna
PROJECT No. 634-CP1914**

OPTION NO. 3 – IKO

8.1 Modified Bitumen Membrane

- 8.1.1 Modified Bitumen Sheets shall conform to CGSB 37-GP-56M “Membrane, Modified, Bituminous, Prefabricated and Reinforced for Roofing”; Type 2, Class C, Grade 2 for Base Sheets and Type 1, Class A, Grade 2 for Cap Sheets.
- 8.1.2 The Contractor may bid on any Manufacturer’s Systems specified for torching application of the base sheet and torching of the cap sheet for this roof area. The colour of the granular surface is to be selected by the Owner. Supply additional granules to be applied to bitumen outflows between membrane sheets.
- 8.1.3 Modified Bitumen Membrane Two-Ply System shall be as specified or approved equal and accepted by the Consultant and Owner.
- a) Soprema**
- i) Base Sheet (TORCHFLEX TP-180-SF-BASE 3.5 mm for Cap Sheet)
 - ii) Self-Adhesive Membrane (ARMOURBOND 180)
 - iii) Cap Sheet (TORCHFLEX TP-250 CAP) for flashing membrane.

8.2 Vapour Retarder

- 8.2.1 IKO MVP Modified Vapour Protector is a self-adhesive membrane composed of SBS modified bitumen and a tri-laminated woven polyethylene facer. The under face is covered with a silicone release film.

8.3 Insulation Support Panel

- 8.3.1 IKO Protectobase 180 is a high-performance high-density support panel composed of SBS modified bitumen membrane with a non-woven polyester reinforcement, factory-laminated on asphaltic board (IKOTHERM). The surface is covered with a thermo-fusible plastic film.

8.4 Primer

- 8.4.1 The primer shall consist of IKO S.A.M. Adhesive designed for use with self-adhered SBS modified bitumen base sheet flashing membrane. The risk of primer flare-up is eliminated when modified bitumen cap sheets are thermo-fused to the self-adhered base sheet flashing membranes.

8.5 Insulation Adhesive

- 8.5.1 Millennium Adhesive is a two-part urethane adhesive to be used for the application of rigid insulation.

8.6 Vent Pipe Stack Flange

- 6.6.1 The vent pipe stack flange shall be Thaler Roofing Specialties Products Inc. Model No. SJ-37 insulated flange. The Roofing Contractor shall verify the inside diameter of the vent pipe stack for each location.

8.0 PRODUCTS

Roof Replacement
for
St. Joseph Catholic School – Corunna
PROJECT No. 634-CP1914

OPTION NO. 3 – IKO

8.7 Hot Exhaust Stack Flashings

- 8.7.1 The hot pipe flashings shall be Thaler Roofing Specialties Products Inc. Model № MEF-3A aluminum flashings with split collar to suit the new Two-Ply Modified Bitumen Roof System. The Roofing Contractor shall verify the inside diameter of the hot pipe stack for each location and fill between the flange and pipe with ROXUL Insulation.

8.8 Roof Drain

- 8.8.1 Roof Drain shall be Thaler Roof Specialties Products Inc. Model No. RD-4-RR with FURCO FOR DIRECT CONNECT. Outlet size shall be verified on site by the Roofing Contractor.

8.9 Rigid Insulation

- 8.9.1 IKOTHERM shall be roof insulation which is rigid closed cell, Polyiso Foam Insulation, integrally laminated to fiber-reinforced paper facers, thermal resistance of insulation shall be R-23.6 (L.T.T.R.) (4.0 inch) for the main roof area and R-11.4 (L.T.T.R.) (2.0 inch) around recessed roof drains, Resistance R-Value in accordance with ASTM C1289-11A. All insulation boards shall be 4 feet by 4 feet in size. **ONLY ROOF AREA 'G', the rigid insulation shall be R-11.4 (L.T.T.R.) (2.0 inch) for the main roof area.**

8.10 Tapered Insulation (Recessed Roof Drains)

- 8.10.1 The tapered insulation shall be faced Isocyanurate Boards conforming to CAN/CGSB-51.26-M86, meeting the requirements of ULC S126 Polyisocyanurate foam panels chemically bonded during the foaming process to facers on the top and bottom organic surfaces. Tapered panels shall not be less than 13m at any point of the roof to the slope indicated on the Roof Plan and Details.

8.11 Elastomeric Modified Bitumen Adhesive

- 8.11.1 IKO COLD GOLD FIELD ADHESIVE is a solvent-free, single component, cold-applied interplay adhesive suitable to be used as a cold applied flood coat with approved stone aggregate on top.

8.12 Metal Flashings

- 8.12.1 Metal flashings shall be 24ga. **Colorite 8000 Series** pre-finished steel (both sides) as manufactured by Westeel Roscoe, **Steelcolour 8000 Series** or Owner approved equal, formed to comply with field conditions. The colour is to be selected by the Owner from the Manufacturer's standard colours. A one meter "test bend" for each general metal flashing condition shall be completed and presented to the Owner's Representative for approval prior to general fabrication.

8.13 Sealants

- 8.13.1 Caulking Sealants for metal flashing shall be one-part silicone to conform to CGSB 19 GP 96. Sealants shall be manufactured by Canadian General Electric, Dow Corning or approved equal. The colour of the sealant shall be identical to the colour of the metal flashing; the Owner is to approve the colour before ordering the sealant. This sealant shall be applied to all metal flashing joints including the reglet.

8.0 PRODUCTS

**Roof Replacement
for
St. Joseph Catholic School – Corunna
PROJECT No. 634-CP1914**

OPTION NO. 3 – IKO

8.14 Roofing Gravel

- 8.14.1 The gravel shall be ¼” to 5/8” size; water washed pea gravel, well graded, opaque, non-porous material free of fines, moisture, ice, and snow or long splinters and conforms to ASTM D1863-086.

8.15 Framing Lumber

- 8.15.1 Framing Lumber on top of roof area shall be pressure treated for rot resistance conforming to CSA 0322-1976 and CSA 080-M1983; sizes shown on the Drawings. Grade SPF No. 2 or better.

8.16 Plywood

- 8.16.1 Exterior Grade “fir” to CSA 0121 or CSA 0151, ½” and ¾” thick, as detailed on Enclosed Drawings.

8.17 Rough Hardware and Nails

- 8.17.1 The Roofing Contractor shall supply all rough hardware where required. Nails, spikes, screws, bolts, etc. shall be of sufficient size and type to rigidly secure all members into place. All nails shall be hot dip galvanized.

8.18 Painting

- 8.18.1 All existing gas lines, exhaust fan hoods and roof top units shall be cleaned and scraped prior to being repainted.
- 8.18.2 Clean and prime with Alkyd Metal Primer before applying two coats of enamel paint. The colour shall be selected by the Owner.

8.19 Plastic Roof Cement

- 8.19.1 Aquabarrier Mastic is a modified asphalt sealant that is formulated with synthetic rubber for longevity and glass fibers for extra strength.

8.20 Precast Pads

- 8.20.1 Precast concrete pads shall be 24 inches by 24 inches by 2-inch-thick for additional walkway, etc. as shown on Roof Plan. Pads shall be placed on a 20 inch by 20 inches by 2-inch-thick sections of rigid Type 4 extruded polystyrene insulation. **(45 new pavers in total)**

8.21 Exhaust Vent Flashings

- 8.21.1 Thaler EVF Exhaust Vent Flashings consist of a double wall metal flashing sleeve with integral deck flange matching removable hood (screw fastened) pre-molded urethane) insulation lines and EPDM base seal.

9.0 EXECUTION

Roof Replacement for St. Joseph Catholic School – Corunna PROJECT No. 634-CP1914

OPTION NO. 3 – IKO

9.1 Tear-Off

- 9.1.1 Prior to the start of installation, the roofing Contractor shall examine all roof areas included in this Specification. The Roofing Contractor shall notify the Consultant of any unacceptable conditions.
- 9.1.2 These conditions include, but are not limited to, uneven deck surfaces, improperly installed curbs and nailers, surfaces with fins or sharp projections, and surfaces contaminated with incompatible materials. Work shall not begin until these conditions have been corrected. Protect membrane in high traffic areas, work by other trades, application of gravel, etc.
- 9.1.3 Completely remove the existing **Built-Up Roof System** completely to the existing metal deck with the exception to Roof Area 'G' where the existing Two-Ply Modified Bitumen Roof Membrane along with ½ inch fiberboard rigid insulation on top the existing Polyiso Rigid Insulation is to be removed only. Only tear-off those roofing components that can be re-roofed in the same day. Tear-off work shall not be left exposed at the end of the work day.

9.2 INSTALLATION – Two Ply Modified Bitumen Membrane Roof System

- 9.2.1 The areas to be re-roofed must have all the roofing components removed completely to the metal roof deck before applying the new roof system. Install all carpentry items such as curb extensions, wood blocking at roof perimeters, etc. as detailed on the Drawings. All wood members which are to be anchored to masonry construction shall be permanently fastened into place. Do not use fasteners which will cause spalling, cracking or deformation of fastened materials.
- 9.2.2 Apply roofing materials over clean and dry surfaces in accordance with the Manufacturer's Recommendations. The re-roofing operations shall be performed on a continuous basis as weather conditions allow.
- 9.2.3 Install all new wood blocking and plywood as detailed on the applicable details.
- 9.2.4 **Installation of Vapour Retarder**
 - .1 When applying IKO MVP over top metal deck, the existing surface is to be primed in accordance with Membrane Manufacturer.
 - .2 The deck surface must be clean and sound, free of loose materials or contaminants such as water and grease which may compromise the performance of this product.
 - .3 Unroll and align air/vapour barrier centered at low point of roof or drain. Apply air/vapour removing release film providing 3-inch side laps and 6-inch end last (minimum). Seal around projections as per manufacturer's recommendations.
 - .4 Apply self-adhesive membrane without any wrinkles or fish mouths.
 - .5 The vapour retarder is to be carried up the vertical surfaces a minimum of 8 inches above roof deck.
- 9.2.5 **Installation of Rigid Insulation Boards**
 - .1 Install boards with MILLENNIUM Adhesive to the vapour retarder. On all insulation surfaces intended for board coverage apply beads of 20mm (3/4") wide on 200mm (8") centers.
 - .2 Firmly set the rigid insulation boards in staggered fashion. All boards must be butted tightly together.
 - .3 Apply only as many boards as can be covered in the same day.

9.0 EXECUTION

Roof Replacement for St. Joseph Catholic School – Corunna PROJECT No. 634-CP1914

OPTION NO. 3 – IKO

9.2.6 Installation of Support Panel

- .1 Install IKO PROTECTOBOARD 180 with MILLENNIUM Adhesive to the rigid insulation as indicated. On all insulation surfaces intended for board coverage, apply continuous strips of 13 to 19 mm (½ to ¾ inch) on 150 mm (6") centers for eight (8) feet around roof perimeter and 200 mm (8") centers for the field of the roof.
- .2 Firmly set the Smart Boards, into the strips of MILLENNIUM Adhesive. All boards must be evenly and tightly butted together in soldier fashion.
- .3 Apply only as many boards as can be covered in the same day.
- .4 Install TORCHTAPE cover strips across the end laps on the panels by heat-welded with a propane torch.

9.2.7 Installation of Additional Plywood and/or Wood Blocking

Install all new wood blocking and plywood as detailed on the applicable Details.

Note: The new plywood detailed on the inside face of parapet wall is not to be installed until the first ply of base sheet roof membrane is applied 3 inches up the vertical surface of parapet wall.

9.2.8 Application of Primer

- .1 Apply IKO S.A.M. primer to the wood blocking and plywood surfaces which will be in contact with the self-adhesive membranes at a rate of 0.2 to 0.3 l/m². All surfaces to be primed must be free of rust, dust or any residue that may hinder adherence. Cover primed surfaces with roofing membrane as directed by the Manufacturer.

9.2.9 Base Sheet Flashing Installation

- .1 Apply base sheet flashing only once primer coat is dry.
- .2 Install base sheet flashing in one (1) metre widths to cover roofing substrate over 100mm. Overlap side laps by 75mm. Stagger side laps by a least 100mm from base sheet overlaps on the roof to avoid excessive layering.
- .3 Apply base sheet flashing directly onto substrate by removing silicone paper cover sheet. Proceed from top to bottom. Once in place, apply pressure manually in a uniformed fashion to obtain homogenous adherence over the entire surface. Preferably seal seams with aluminum applicator and rubber roller. The flashing membrane is to be adhered 4 inches over top of the Blueskin membrane on the outside face of parapet wall. Nail outside edge at 300mm O.C. Burn off plastic film of base sheet membrane before adhering base sheet flashing over it.
- .4 Avoid forming wrinkles, air pockets or fish-mouths.

Note: ALL BASE SHEET FLASHING MEMBRANES ARE TO BE EXTENDED TO THE BOTTOM OF WOOD FASCIA.

9.0 EXECUTION

**Roof Replacement
for
St. Joseph Catholic School – Corunna
PROJECT No. 634-CP1914**

OPTION NO. 3 – IKO

9.2.10 **Cap Sheet Installation**

- .1 Prior to installing the cap sheet membrane, all insulated flanges are to be installed around each roof penetration and secured to the metal roof deck with four (4) fasteners per flange before applying base sheet target section on top.
- .2 Once the base sheet has been applied, the stripping has been completed and no indications of defects are present, then the cap sheet shall be laid.
- .3 Begin application of the cap sheet at the lowest edge. Cap sheet shall be unrolled and care be taken to ensure proper alignment of the first roll.
- .4 Cap sheet shall be torched into place in accordance with the Recommendations of the Membrane Manufacturer, to the base sheet membrane.
- .5 The seams between the base sheet and cap sheet shall be staggered a minimum of 300 mm (12 inches).
- .6 Care should be taken to ensure heating is consistent across the width in order to avoid skips or voids. Bitumen should flow out from the lap 6mm (1/4") to ensure a tight seal.
- .7 All lap seams on the cap sheet are to be checked after membrane installation.

9.2.11 **Cap Sheet Flashing Installation**

- .1 Cap sheet membrane installation shall be laid in strips 1m wide along the parapet. Side laps shall be a minimum of 100mm (4 inches) overlap.
- .2 Extend cap sheet a minimum of 150mm (6 inches) onto roof surface from the intersection of roof and vertical surfaces and extend to the top of the parapet wall to the outside of wall.
- .3 The flashing membrane shall be anchored to the wood nailers by nailing through discs or using nails with 25mm (1 inch) minimum diameter head semi-solidly attached. Nail a minimum of 200mm (8 inches) on center.
- .4 Matching granules shall be used to cover excess between flow at seams.

9.2.12 **Flood Coat and Gravel Cover**

- .1 Apply a flood coat of cold roofing adhesive (COLD GOLD) at the rate of 5 gallons/100ft² as recommended by Manufacturer (IKO).
- .2 Then embed new approved pea stone gravel at 20 kg/m² (450 lbs/100ft²) while adhesive is still wet.

9.2.13 **Concrete Pavers**

- .1 Install concrete pavers as indicated on the Roof Plan on top of one-inch extruded polystyrene rigid insulation (Type 4).

9.0 EXECUTION

**Roof Replacement
for
St. Joseph Catholic School – Corunna
PROJECT No. 634-CP1914**

OPTION NO. 3 – IKO

9.3 INSTALLATION – Metal Flashings

- 9.3.1 Cap and counter flashings shall be jointed with a double S-type locked joint. Flashings shall be installed with continuous clips secured to wood capping blocking at 12 inches O.C.
- 9.3.2 Flashing shall be fabricated to shapes on site with all necessary breaks for adequate expansion.
- 9.3.3 The inside face of the metal cap flashing between the S-locked joints is to be secured with three (3) fasteners matching the colour of the metal cap with a neoprene washer between the fastener head and inside face of the metal cap flashing.
- 9.3.4 All joints shall be sealed with approved sealant.
- 9.3.5 Counter flashings shall be installed at all reglets and curbs with at least three (3) inches below the top of roof curb or reglet.

9.4 CLEAN-UP

- 7.4.1 Upon completion of the installation, the work shall be left clean and free of defects which might affect the durability or appearance of the building. Clean all roof surfaces, including adjacent roofs and grounds of all foreign matter resulting from this Roofing Project.

ROOF REPLACEMENT

FOR

**ST. JOSEPH CATHOLIC SCHOOL
535 BIRCHBANK DRIVE
CORUNNA ONTARIO
N0N 1G0**

PROJECT No. 634-CP1914

ENCLOSED DRAWINGS

- R-1 Key Roof Plan
- R-1a Existing and Design Roof System List
- R-2 Enlarged Roof Plan – Roof ‘A’ and ‘B’
- R-3 Enlarged Roof Plan – Roof ‘C’
- R-4 Enlarged Roof Plan – Roof ‘D’ and ‘E’
- R-5 Enlarged Roof Plan – Roof ‘F’
- R-6 Enlarged Roof Plan – Roof ‘G’

- D-1 Roof Detail – Area ‘A’
- D-2 Roof Parapet Detail – Area ‘A’
- D-3 Roof Parapet Detail – Area ‘B’
- D-4 Exhaust Fan Detail
- D-5 Roof Drain Detail
- D-6 Vent Pipe Stack Detail
- D-7 Roof Parapet Detail – Area ‘C’, ‘D’, ‘E’ and ‘F’
- D-8 Skylight Detail
- D-9 Exhaust Vent Flashing Detail
- D-10 Hot Exhaust Stack Detail
- D-11 Relief Vent Detail
- D-12&12a Wall Ladder Detail
- D-13 Roof Drain Detail – Area ‘G’
- D-14 Vent Pipe Stack Detail– Area ‘G’
- D-15 Roof Parapet Detail – Area ‘G’
- D-16 Control Joint Detail

 AREA OF ROOF TO BE REMOVED COMPLETELY TO THE METAL DECK AND REPLACED W/ NEW ROOF SYSTEM

 AREA OF EXISTING ROOF MEMBRANE TO BE REMOVED ONLY AND REPLACED W/ NEW ROOF SYSTEM

 **KEY ROOF PLAN**
SCALE : 1" = 30'-0"

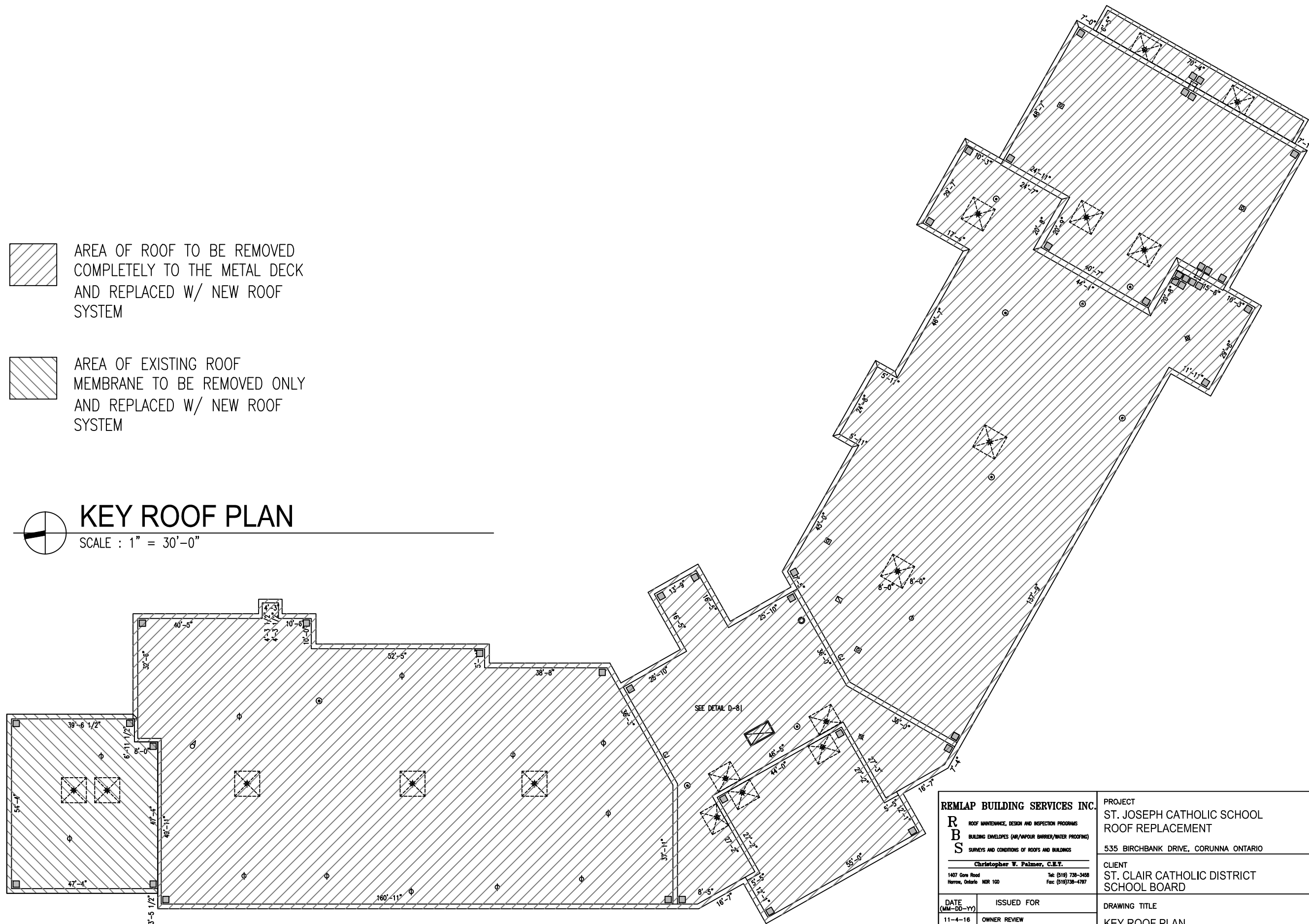

REMLAP BUILDING SERVICES INC.		PROJECT	DATE :	NOVEMBER 2016
R B S		ST. JOSEPH CATHOLIC SCHOOL ROOF REPLACEMENT	SCALE :	AS SHOWN
ROOF MAINTENANCE, DESIGN AND INSPECTION PROGRAMS BUILDING ENVELOPES (AIR/WAPOUR BARRIER/WATER PROOFING) SURVEYS AND CONDITIONS OF ROOFS AND BUILDINGS		535 BIRCHBANK DRIVE, CORUNNA ONTARIO	DRAWN BY :	CWP
Christopher W. Palmer, C.E.T.		CLIENT	CHK. BY :	CWP
1407 Gore Road Harvey, Ontario N0R 1G0 Tel: (519) 738-3458 Fax: (519) 738-4787		ST. CLAIR CATHOLIC DISTRICT SCHOOL BOARD	SHEET SIZE :	11"x17"
DATE (MM-DD-YY)	ISSUED FOR	DRAWING TITLE	PROJECT FILE NO.	RBS16-62
11-4-16	OWNER REVIEW	KEY ROOF PLAN	DRAWING NO.	R-1
03-05-19	TENDER			

**ROOF REPLACEMENT
ST. JOSEPH CATHOLIC SCHOOL
535 BIRCHBANK DRIVE, CORUNNA ONTARIO N0N 1G0**

EXISTING ROOF SYSTEM**DESIGN ROOF SYSTEM****AREA 'A'**

Flood Coat of Asphalt w/Granules
On 4 Plies of Roofing Felt w/Asphalt
On 1/2" Fiberboard Insulation
On 1.7" Rigid Insulation (ISO)
On Kraft Paper for Vapour Retarder
On 1½" Metal Deck

Pea Stone Roofing Gravel
On Flood Coat of Adhesive
On Two Ply Modified Bitumen Membrane
On 3/16" Asphalt Protection Board
On Tapered Insulation as Noted
On 4" Rigid Insulation (ISO)
On Vapour Retarder as Specified
On Existing Metal Deck

AREA 'B'

Flood Coat of Asphalt w/Granules
On 4 Plies of Roofing Felt w/Asphalt
On ½" Fiberboard Insulation
On 1.5" Rigid Insulation (ISO)
On Kraft Paper for Vapour Retarder
On 3" Acoustic Metal Deck w/Flutes Filled w/Fiberglass Batt

Pea Stone Roofing Gravel
On Flood Coat of Adhesive
On Two Ply Modified Bitumen Membrane
On 3/16" Asphalt Protection Board
On Tapered Insulation as Noted
On 4" Rigid Insulation (ISO)
On Vapour Retarder as Specified
On Existing Acoustic Metal Deck

AREA 'C'

Flood Coat of Asphalt w/Granules
On 4 Plies of Roofing Felt w/Asphalt
On 1/2" Fiberboard Insulation
On 1.7" Rigid Insulation (ISO)
On Kraft Paper for Vapour Retarder
On 1½" Metal Deck

Pea Stone Roofing Gravel
On Flood Coat of Adhesive
On Two Ply Modified Bitumen Membrane
On 3/16" Asphalt Protection Board
On Tapered Insulation as Noted
On 4" Rigid Insulation (ISO)
On Vapour Retarder as Specified
On Existing Metal Deck

AREA 'D'

Flood Coat of Asphalt w/Granules
On 4 Plies of Roofing Felt w/Asphalt
On 1/2" Fiberboard Insulation
On 1.5" Rigid Insulation (ISO)
On Kraft Paper for Vapour Retarder
On 1½" Metal Deck

Pea Stone Roofing Gravel
On Flood Coat of Adhesive
On Two Ply Modified Bitumen Membrane
On 3/16" Asphalt Protection Board
On Tapered Insulation as Noted
On 4" Rigid Insulation (ISO)
On Vapour Retarder as Specified
On Existing Metal Deck

EXISTING ROOF SYSTEM

Flood Coat of Asphalt w/Granules
On 4 Plies of Roofing Felt w/Asphalt
On 1/2" Fiberboard Insulation
On 1.5" Rigid Insulation (ISO)
On Kraft Paper for Vapour Retarder
On 1½" Metal Deck

AREA 'E'

DESIGN ROOF SYSTEM

Pea Stone Roofing Gravel
On Flood Coat of Adhesive
On Two Ply Modified Bitumen Membrane
On 3/16" Asphalt Protection Board
On Tapered Insulation as Noted
On 4" Rigid Insulation (ISO)
On Vapour Retarder as Specified
On Existing Metal Deck

Flood Coat of Asphalt w/Granules
On 4 Plies of Roofing Felt w/Asphalt
On 1/2" Fiberboard Insulation
On 1.7" Rigid Insulation (ISO)
On Kraft Paper for Vapour Retarder
On 1½" Metal Deck

AREA 'F'

Pea Stone Roofing Gravel
On Flood Coat of Adhesive
On Two Ply Modified Bitumen Membrane
On 3/16" Asphalt Protection Board
On Tapered Insulation as Noted
On 4" Rigid Insulation (ISO)
On Vapour Retarder as Specified
On Existing Metal Deck

AREA 'G'

Two Ply Modified Bitumen Granulated Surface Membrane
On ½" Fibreboard Insulation
On 3.2" Rigid Insulation (ISO)
On Kraft Paper for Vapour Retarder
On ½" Gypsum Board
On 1½" Metal Deck

Pea Stone Roofing Gravel
On Flood Coat of Adhesive
On Two Ply Modified Bitumen Membrane
On 3/16" Asphalt Protection Board
On Tapered Insulation as Noted
On New 2" Rigid Insulation (ISO)
On Existing 3.2" Rigid Insulation
On Existing Vapour Retarder
On Existing ½" Gypsum Board
On Existing Metal Deck

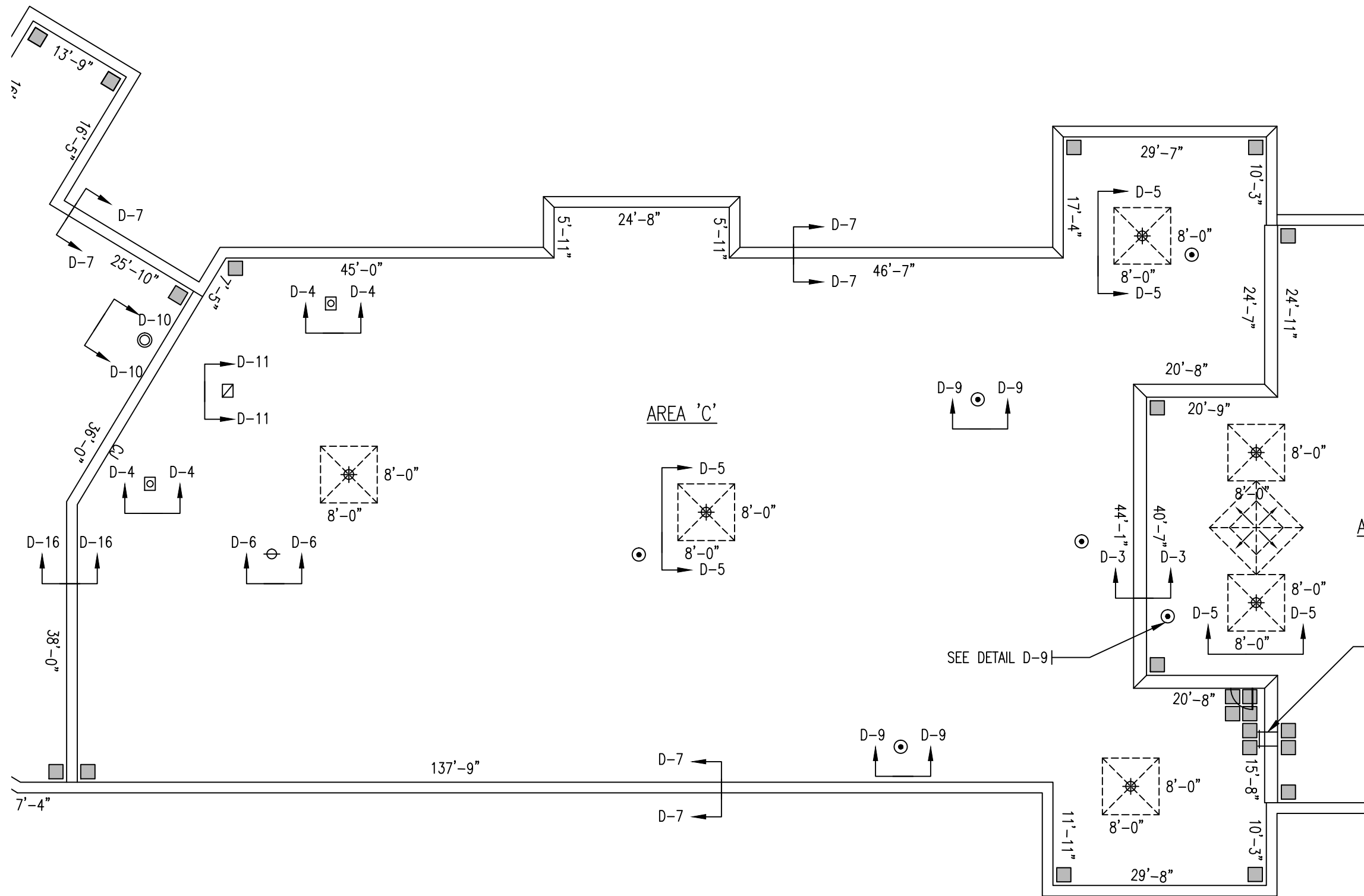

LEGEND	
	ROOF DRAIN
	VENT PIPE STACK
	EXHAUST FAN
	WALL LADDER
	BRACKET FOR EXTENSION LADDER
	ABANDONED CURB TO BE ELIMINATED
	HOT EXHAUST STACK
	EXHAUST STACK W/ DIRECTION
	GOOSE NECK EXHAUST FAN
	CONTROL JOINT
	CONCRETE PAVER W/ INSULATION CUSHION
	EXHAUST VENT FLASHING
	SKYLIGHT

TAPERED INSULATION
 ROOF DRAIN - 2% SLOPE
 CRICKETS - 1% SLOPE

ENLARGED ROOF PLAN - ROOF PENETRATION AND DIMENSIONS
 SCALE : 1/16" = 1'-0"

REMLAP BUILDING SERVICES INC. ROOF MAINTENANCE, DESIGN AND INSPECTION PROGRAMS BUILDING ENVELOPES (AIR/WAPOUR BARRIER/WATER PROOFING) SURVEYS AND CONDITIONS OF ROOFS AND BUILDINGS Christopher W. Palmer, C.E.T. 1407 Gore Road, Huron, Ontario N0R 1G0 Tel: (519) 738-3458 Fax: (519) 738-4797	PROJECT ST. JOSEPH CATHOLIC SCHOOL ROOF REPLACEMENT 535 BIRCHBANK DRIVE, CORUNNA ONTARIO	DATE : NOVEMBER 2016 SCALE : AS SHOWN DRAWN BY : CWP
	CLIENT ST. CLAIR CATHOLIC DISTRICT SCHOOL BOARD	CHK. BY : CWP SHEET SIZE : 11"x17"
	DRAWING TITLE ENLARGED ROOF PLAN - ROOF 'C'	PROJECT FILE NO. RBS16-62 DRAWING NO. R-3

DATE (MM-DD-YY)	ISSUED FOR
11-4-16	OWNER REVIEW
03-05-19	TENDER

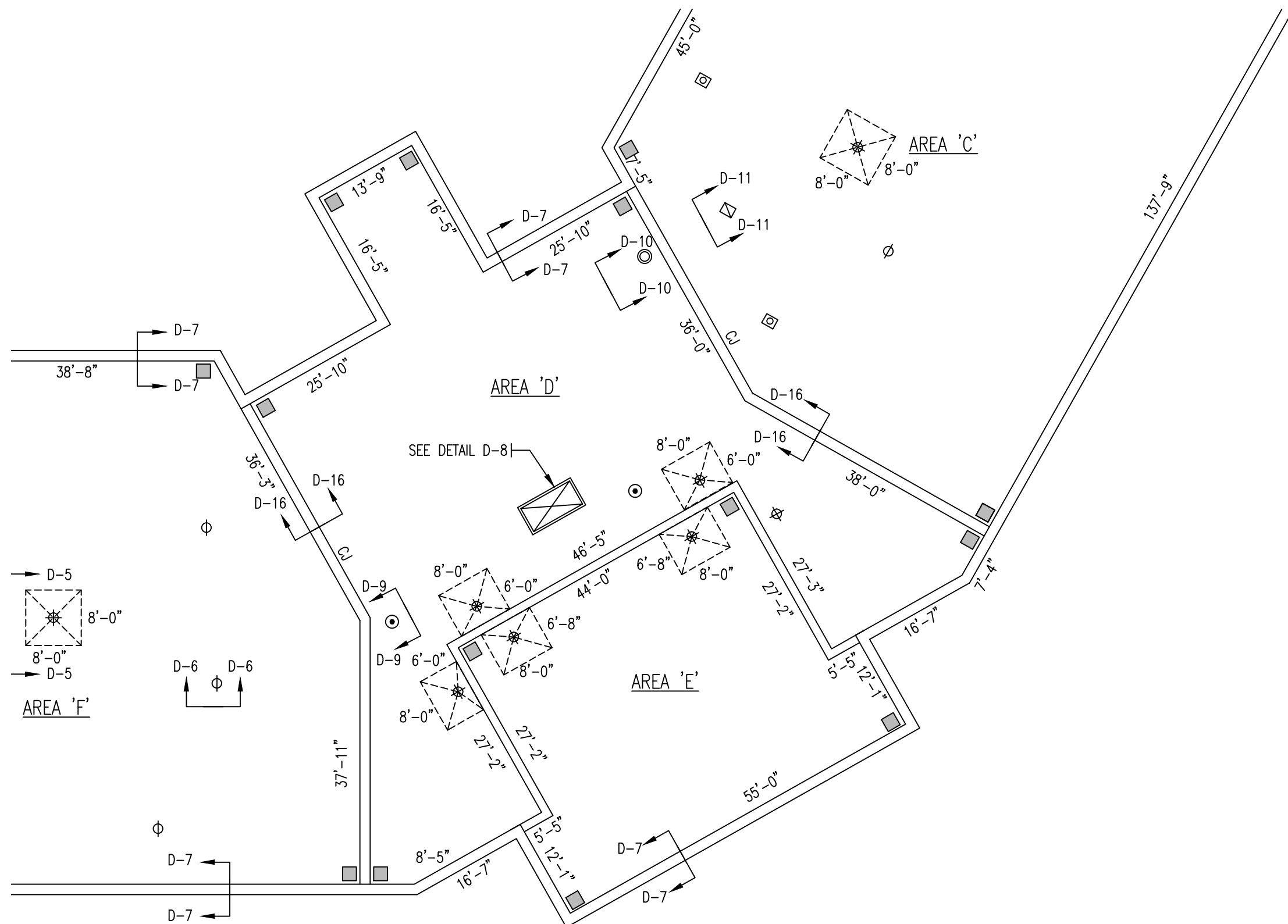

LEGEND	
	ROOF DRAIN
	VENT PIPE STACK
	EXHAUST FAN
	WALL LADDER
	BRACKET FOR EXTENSION LADDER
	ABANDONED CURB TO BE ELIMINATED
	HOT EXHAUST STACK
	EXHAUST STACK W/ DIRECTION
	GOOSE NECK EXHAUST FAN
	CONTROL JOINT
	CONCRETE PAVER W/ INSULATION CUSHION
	EXHAUST VENT FLASHING
	SKYLIGHT

TAPERED INSULATION
 ROOF DRAIN - 2% SLOPE
 CRICKETS - 1% SLOPE

ENLARGED ROOF PLAN - ROOF PENETRATION AND DIMENSIONS
 SCALE : 1/16" = 1'-0"

REMLAP BUILDING SERVICES INC. ROOF MAINTENANCE, DESIGN AND INSPECTION PROGRAMS BUILDING ENVELOPES (AIR/WATER BARRIER/WATER PROOFING) SURVEYS AND CONDITIONS OF ROOFS AND BUILDINGS Christopher W. Palmer, C.E.T. 1407 Gore Road, Huron, Ontario N0R 1G0 Tel: (519) 738-3458 Fax: (519) 738-4787	PROJECT ST. JOSEPH CATHOLIC SCHOOL ROOF REPLACEMENT 535 BIRCHBANK DRIVE, CORUNNA ONTARIO	DATE : NOVEMBER 2016 SCALE : AS SHOWN DRAWN BY : CWP
	CLIENT ST. CLAIR CATHOLIC DISTRICT SCHOOL BOARD	CHK. BY : CWP SHEET SIZE : 11"x17"
DATE (MM-DD-YY) 11-4-16 03-05-19	ISSUED FOR OWNER REVIEW TENDER	DRAWING TITLE ENLARGED ROOF PLAN - ROOF 'C', 'D', 'E' AND 'F'
		PROJECT FILE NO. RBS16-62 DRAWING NO. R-4

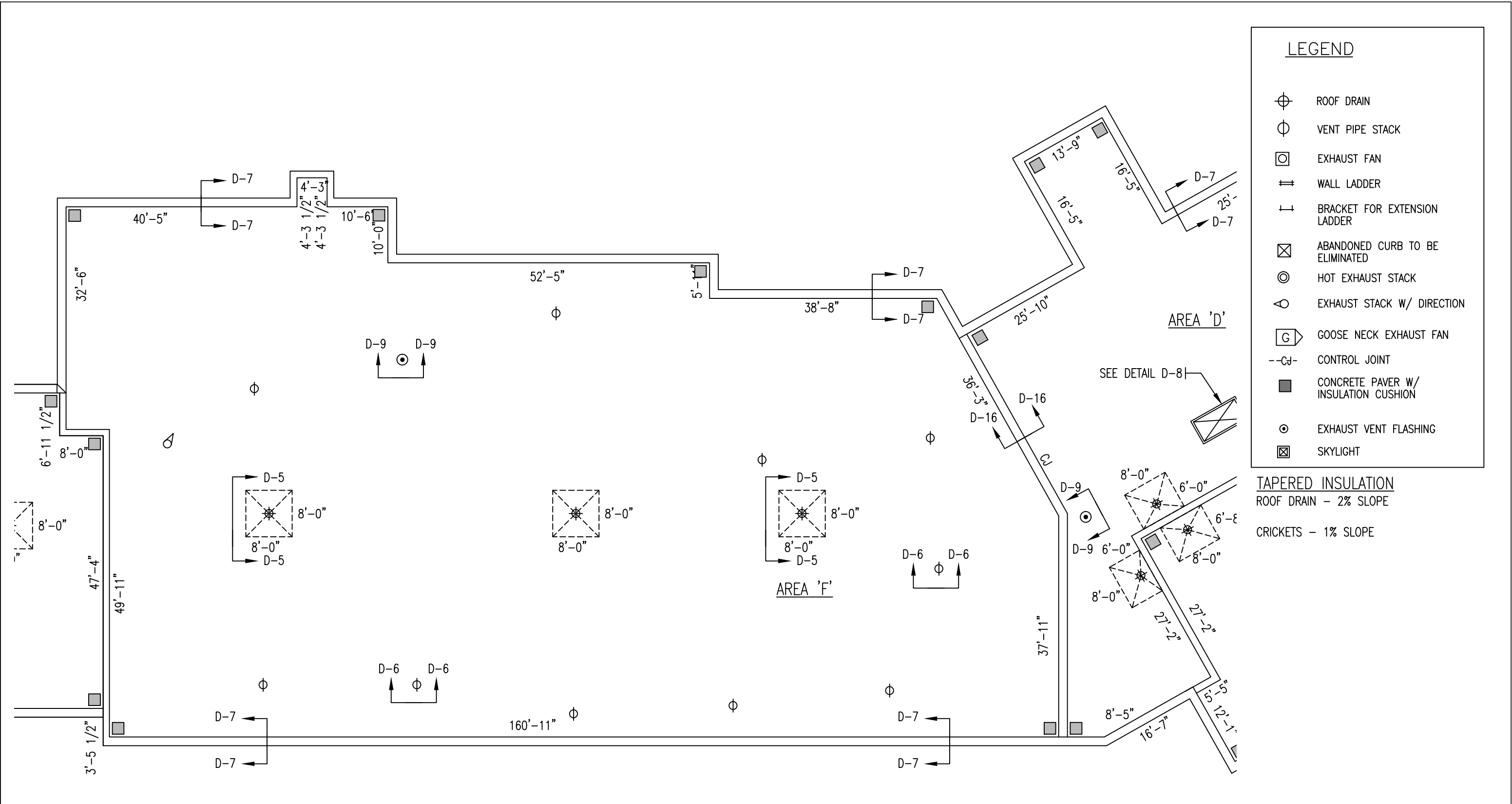

LEGEND	
	ROOF DRAIN
	VENT PIPE STACK
	EXHAUST FAN
	WALL LADDER
	BRACKET FOR EXTENSION LADDER
	ABANDONED CURB TO BE ELIMINATED
	HOT EXHAUST STACK
	EXHAUST STACK W/ DIRECTION
	GOOSE NECK EXHAUST FAN
	CONTROL JOINT
	CONCRETE PAVER W/ INSULATION CUSHION
	EXHAUST VENT FLASHING
	SKYLIGHT

TAPERED INSULATION
 ROOF DRAIN - 2% SLOPE
 CRICKETS - 1% SLOPE

ENLARGED ROOF PLAN - ROOF PENETRATION AND DIMENSIONS
 SCALE : 1/16" = 1'-0"

REMLAP BUILDING SERVICES INC. ROOF MAINTENANCE, DESIGN AND INSPECTION PROGRAMS BUILDING ENVELOPES (AIR/WAPOUR BARRIER/WATER PROOFING) SURVEYS AND CONDITIONS OF ROOFS AND BUILDINGS Christopher W. Palmer, C.E.T. 1407 Gore Road, Toronto, Ontario M6R 1G0 Tel: (519) 738-3458 Fax: (519) 738-4787	PROJECT ST. JOSEPH CATHOLIC SCHOOL ROOF REPLACEMENT 535 BIRCHBANK DRIVE, CORUNNA ONTARIO	DATE : NOVEMBER 2016 SCALE : AS SHOWN DRAWN BY : CWP CHK. BY : CWP SHEET SIZE : 11"x17"
	CLIENT ST. CLAIR CATHOLIC DISTRICT SCHOOL BOARD	PROJECT FILE NO. RBS16-62 DRAWING NO. R-5
	DATE (MM-DD-YY) 11-4-16 03-05-19	ISSUED FOR OWNER REVIEW TENDER

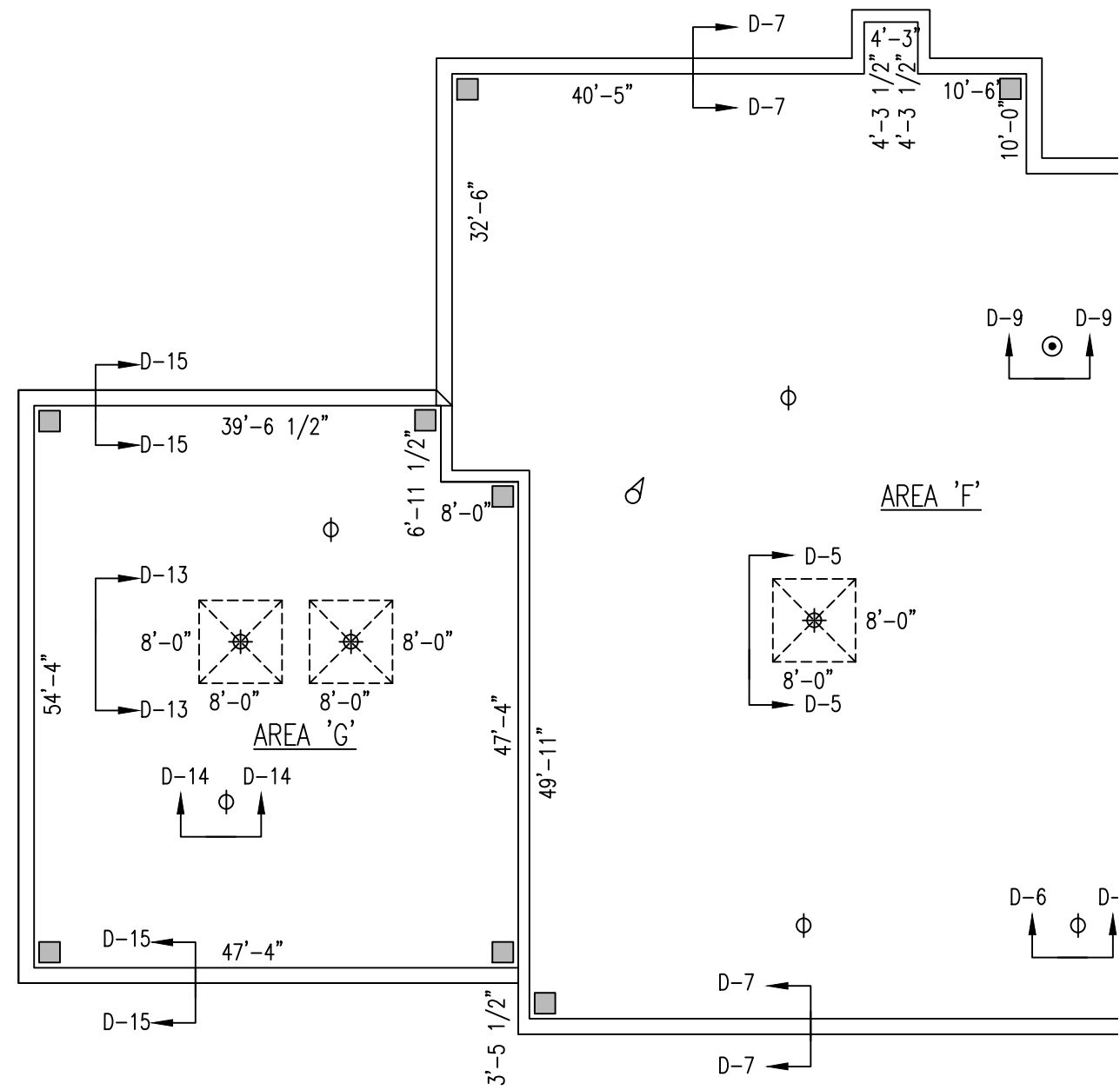

LEGEND

- ⊕ ROOF DRAIN
- ⊙ VENT PIPE STACK
- ⊞ EXHAUST FAN
- ≡ WALL LADDER
- ⊥ BRACKET FOR EXTENSION LADDER
- ⊠ ABANDONED CURB TO BE ELIMINATED
- ⊙ HOT EXHAUST STACK
- ⊙ EXHAUST STACK W/ DIRECTION
- ⊞ GOOSE NECK EXHAUST FAN
- CJ- CONTROL JOINT
- CONCRETE PAVER W/ INSULATION CUSHION
- ⊙ EXHAUST VENT FLASHING
- ⊠ SKYLIGHT

TAPERED INSULATION

ROOF DRAIN - 2% SLOPE

CRICKETS - 1% SLOPE



ENLARGED ROOF PLAN - ROOF PENETRATION AND DIMENSIONS

SCALE : 1/16" = 1'-0"

REMLAP BUILDING SERVICES INC. ROOF MAINTENANCE, DESIGN AND INSPECTION PROGRAMS BUILDING ENVELOPES (AIR/WAPOUR BARRIER/WATER PROOFING) SURVEYS AND CONDITIONS OF ROOFS AND BUILDINGS Christopher W. Palmer, C.E.T. 1407 Gore Road, Huron, Ontario N0R 1G0 Tel: (519) 738-3458 Fax: (519) 738-4787		PROJECT	DATE :	NOVEMBER 2016
		ST. JOSEPH CATHOLIC SCHOOL ROOF REPLACEMENT	SCALE :	AS SHOWN
		535 BIRCHBANK DRIVE, CORUNNA ONTARIO	DRAWN BY :	CWP
		CLIENT	CHK. BY :	CWP
		ST. CLAIR CATHOLIC DISTRICT SCHOOL BOARD	SHEET SIZE :	11"x17"
DATE (MM-DD-YY)	ISSUED FOR	DRAWING TITLE	PROJECT FILE NO.	RBS16-62
11-4-16	OWNER REVIEW	ENLARGED ROOF PLAN - ROOF 'F' AND 'G'	DRAWING NO.	R-6
03-05-19	TENDER			

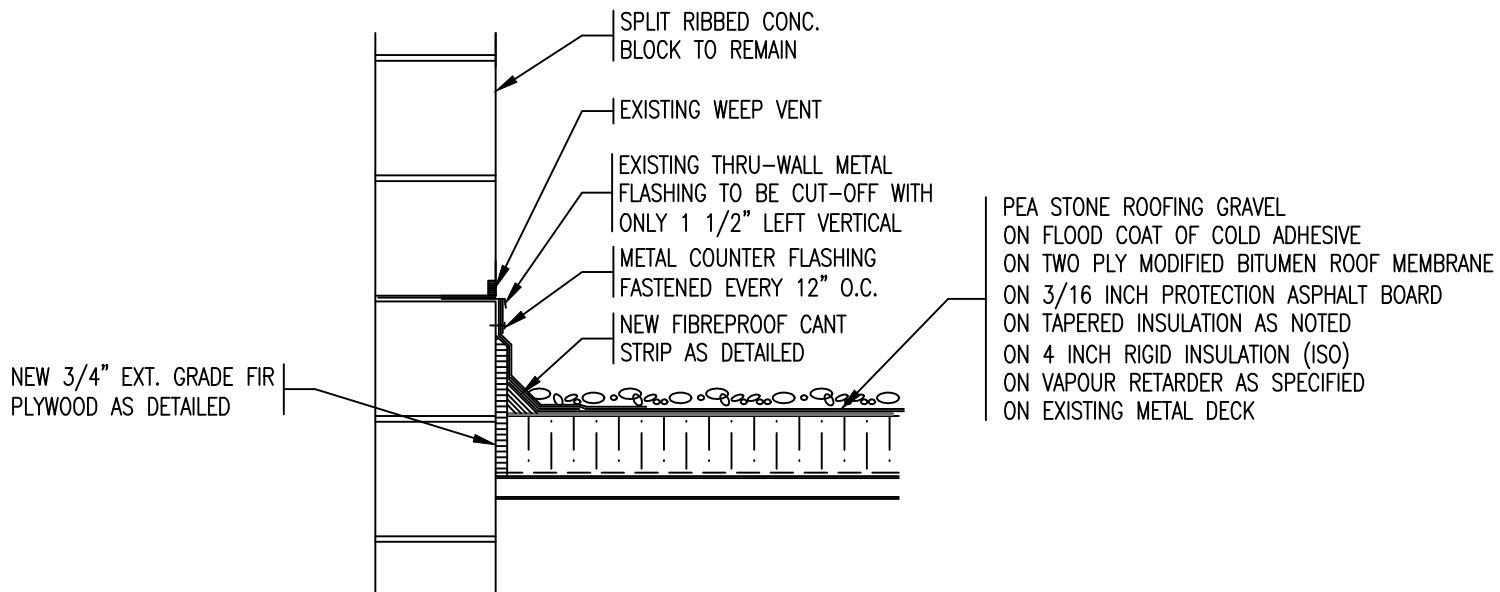

ROOF DETAIL - AREA 'A'

SCALE : 1" = 1'-0"

REMLAP BUILDING SERVICES INC. R B S <small>ROOF ASSESSMENT, DESIGN AND INSPECTION SERVICES ROOFING CONTRACTORS (S/S) (W/OUR OWNERS/OTHER PROJECTS) SUBJECTS AND CONSULTANTS OF ROOFS AND BUILDINGS</small> <small>Christopher W. Palmer, C.E.S.</small> <small>1607 Glen Road Huron, Ontario N2R 1K0</small>	PROJECT ST. JOSEPH CATHOLIC SCHOOL ROOF REPLACEMENT	DATE : NOVEMBER 2016 SCALE : N.T.S.
	535 BIRCHBANK DRIVE., CORUNNA ONTARIO	DRAWN BY : CWP
	CLIENT ST. CLAIR CATHOLIC DISTRICT SCHOOL BOARD	CHK. BY : CWP SHEET SIZE : 8.1/2"x11"
DATE (02-25-17) 11-0-16 OWNER REVIEW 03-05-19 TENDER	ISSUED FOR ROOF DETAIL	PROJECT FILE NO. RBS16-62 DRAWING NO. D-1

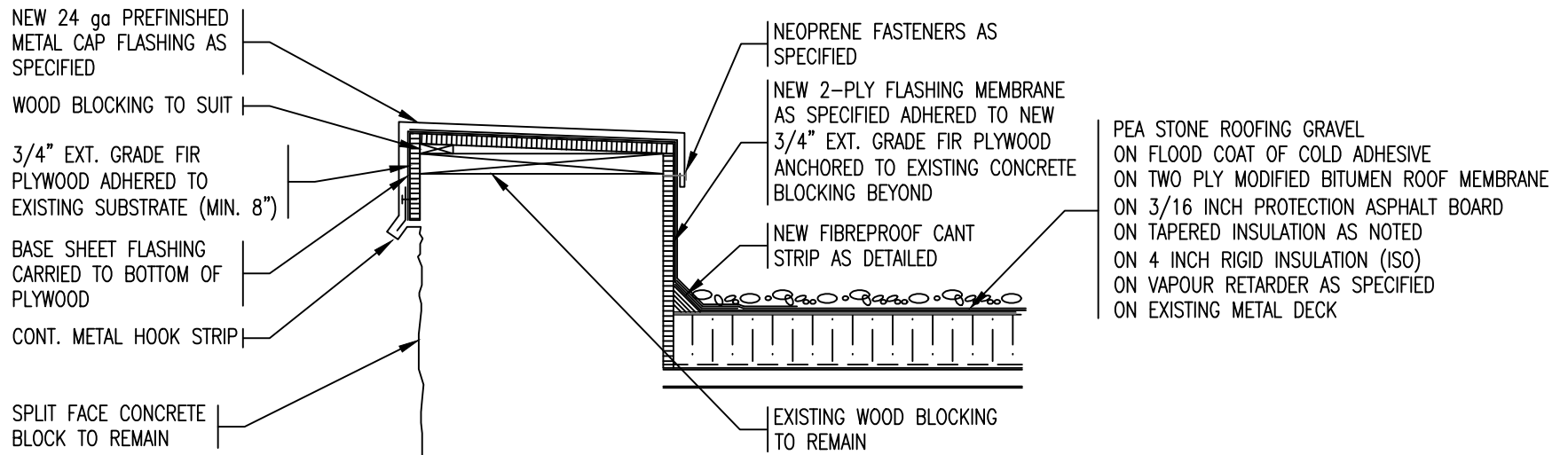

ROOF PARAPET DETAIL - AREA 'A'

SCALE : 1" = 1'-0"

REMLAP BUILDING SERVICES INC. R ROOF REPAIRS, ROOFING AND ROOFING PRODUCTS B BUSINESS DEVELOPMENT (NEW/REPAIR/MAINTENANCE PRODUCTS) S SERVICES AND CONSULTING OF ROOFS AND BUILDINGS <small>1607 Glen Road Toronto, Ontario M8Z 1X2</small>	PROJECT ST. JOSEPH CATHOLIC SCHOOL ROOF REPLACEMENT	DATE : NOVEMBER 2016
	CLIENT ST. CLAIR CATHOLIC DISTRICT SCHOOL BOARD	SCALE : N.T.S.
	DRAWING TITLE ROOF DETAIL	DRAWN BY : CWP
	PROJECT FILE NO. RBS16-62	CHECK BY : CWP
DATE 11-05-16 03-05-19	ISSUED FOR OWNER REVIEW TENDER	SHEET SIZE : 8.1/2"x11"
DRAWING NO. D-2		

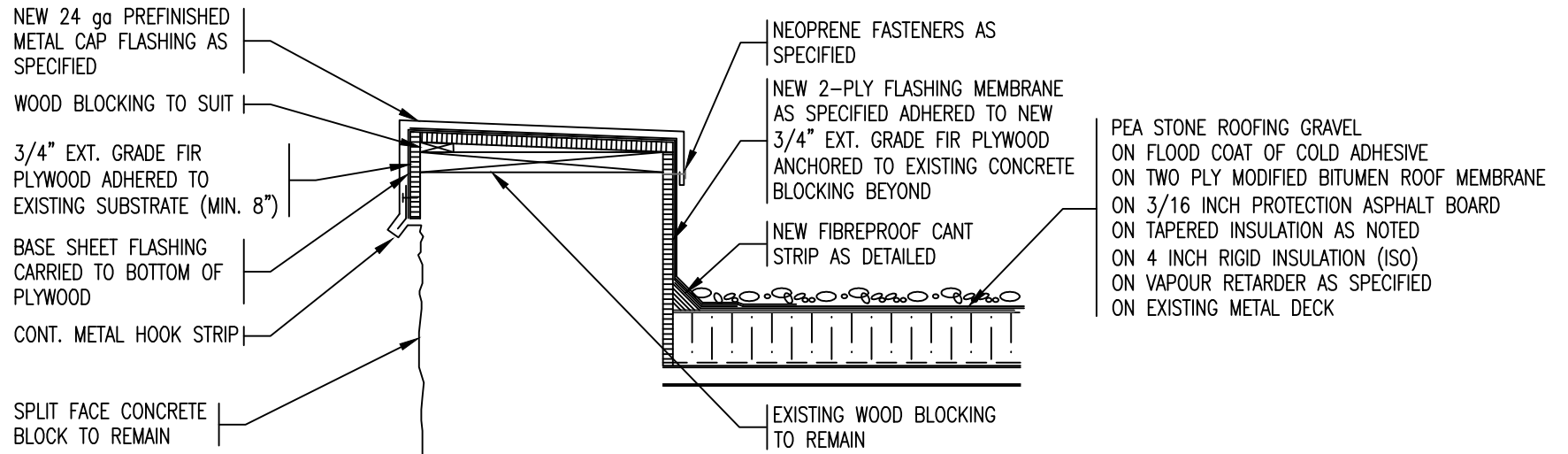

ROOF PARAPET DETAIL - AREA 'B'

SCALE : 1" = 1'-0"

REMLAP BUILDING SERVICES INC. R B S <small>ROOF MEMBRANES, FLASHING AND DRAINAGE PRODUCTS INSULATION MATERIALS (POLYURETHANE FOAMS/FOAM PRODUCTS) SURFACES AND COATINGS OF ROOFS AND WALLS</small> <small>1407 Glen Road Toronto, Ontario M8Z 1X2</small>	PROJECT ST. JOSEPH CATHOLIC SCHOOL ROOF REPLACEMENT	DATE : NOVEMBER 2016
	CLIENT ST. CLAIR CATHOLIC DISTRICT SCHOOL BOARD	SCALE : N.T.S.
	535 BIRCHBANK DRIVE., CORUNNA ONTARIO	DRAWN BY : CWP
	CHECKED BY : W. Palmer, C.E.S.	CHK. BY : CWP
1407 Glen Road Toronto, Ontario M8Z 1X2	Tel: (416) 738-3888 Fax: (416) 738-4027	SHEET SIZE : 8.1/2"x11"
DATE (DD-MM-YY) 11-05-16	ISSUED FOR OWNER REVIEW	PROJECT FILE NO. RBS16-62
03-05-19	TENDER	DRAWING NO. D-3

NEW PREFINISHED METAL
COUNTER FLASHING AS
DETAILED

PEA STONE ROOFING GRAVEL
ON FLOOD COAT OF COLD ADHESIVE
ON TWO PLY MODIFIED BITUMEN ROOF MEMBRANE
ON 3/16 INCH PROTECTION ASPHALT BOARD
ON TAPERED INSULATION AS NOTED
ON 4 INCH RIGID INSULATION (ISO)
ON VAPOUR RETARDER AS SPECIFIED
ON EXISTING METAL DECK

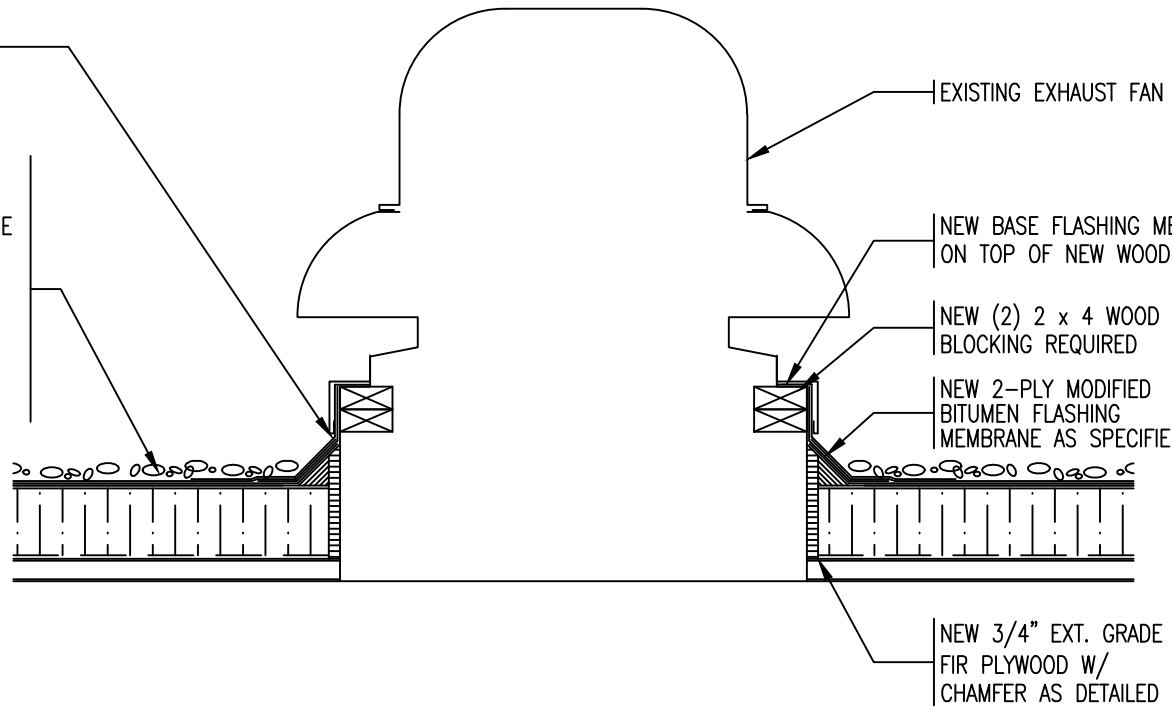

DETAIL - EXHAUST FAN

SCALE : 1" = 1'-0"

REMLAP BUILDING SERVICES INC. R B S <small>1607 Glen Road Aurora, Ontario M1R 1A1</small>	<small>ROOF REPAIRS, ROOFING AND ROOFING PRODUCTS</small> <small>INSULATION SPECIALISTS (POLYURETHANE SPRAY/FORCE APPLIED)</small> <small>SUBJECTS AND CONSULTANTS OF ROOFS AND BUILDINGS</small> <small>Chartered by W. Palmer, C.B.E.</small>	PROJECT ST. JOSEPH CATHOLIC SCHOOL ROOF REPLACEMENT 535 BIRCHBANK DRIVE., CORUNNA ONTARIO	DATE : NOVEMBER 2016 SCALE : N.T.S. DRAWN BY : CWP
	<small>1607 Glen Road Aurora, Ontario M1R 1A1</small>	CLIENT ST. CLAIR CATHOLIC DISTRICT SCHOOL BOARD	CHK. BY : CWP SHEET SIZE : 8.1/2"x11"
	DATE (03-05-17) 11-04-16 OWNER REVIEW 03-05-19 TENDER	ISSUED FOR OWNER REVIEW TENDER	DRAWING TITLE ROOF DETAIL

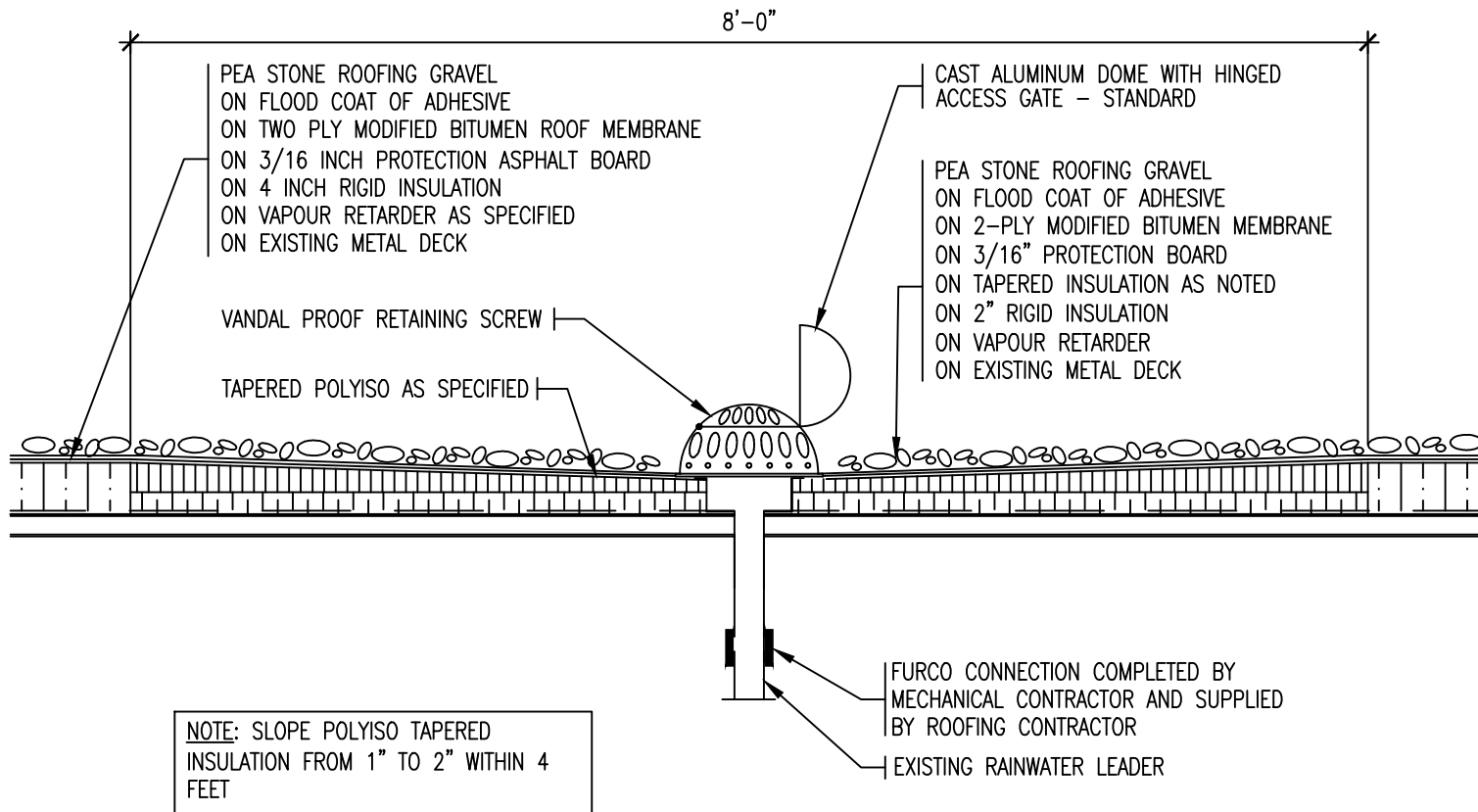

ROOF DETAIL - ROOF DRAIN

SCALE : 1" = 1'-0"

REMLAP BUILDING SERVICES INC. R B S <small>WEATHER RESISTANT SYSTEMS AND ROOFING PRODUCTS INSULATION SPECIALISTS (POLYURETHANE FOAMS/FOAM PRODUCTS) SURFACES AND COMPONENTS OF ROOFS AND BUILDINGS</small> <small>Christopher W. Palmer, C.B.S.</small> <small>1607 Glen Road Toronto, Ontario M8Z 1G2</small>	PROJECT ST. JOSEPH CATHOLIC SCHOOL ROOF REPLACEMENT	DATE : NOVEMBER 2016 SCALE : N.T.S. DRAWN BY : CWP
	CLIENT ST. CLAIR CATHOLIC DISTRICT SCHOOL BOARD	CHECK BY : CWP SHEET SIZE : 8.1/2"x11"
	DRAWING TITLE ROOF DETAIL	PROJECT FILE NO. RBS16-62 DRAWING NO. D-5
DATE 11-04-16 03-05-19	ISSUED FOR OWNER REVIEW TENDER	

NOTE:
 IF EXISTING VENT STACK IS NOT
 HIGHER THAN THE NEW SJ-37,
 THE CONTRACTOR IS REQUIRED TO
 EXTEND A MINIMUM OF 3" ABOVE
 EPDM GROMMET SEAL

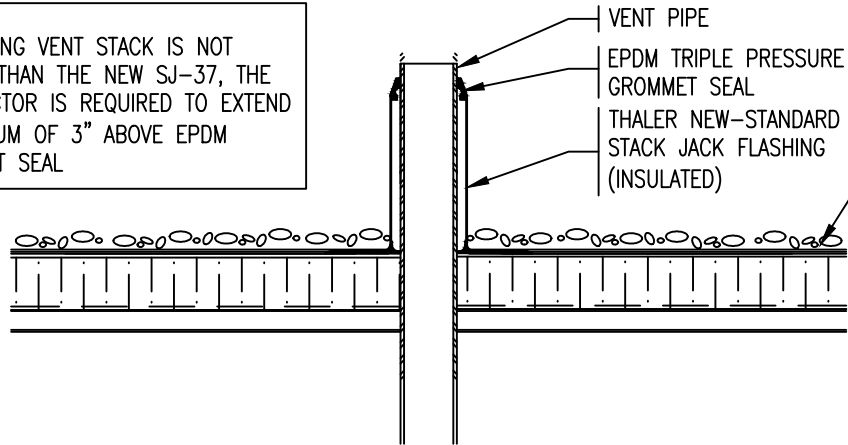

PEA STONE ROOFING GRAVEL
 ON FLOOD COAT OF ADHESIVE
 ON 2-PLY MODIFIED BITUMEN MEMBRANE
 ON 3/16" PROTECTION BOARD
 ON 4" RIGID INSULATION (ISO)
 ON VAPOUR RETARDER AS SPECIFIED
 ON EXISTING METAL DECK

ROOF DETAIL - VENT PIPE STACK

SCALE : 1" = 1'-0"

REMLAP BUILDING SERVICES INC. R B S <small>ROOF ASSESSMENT, DESIGN AND SUPERVISION PROGRAMS INSULATION CHALLENGER (R20/ROOFING MEMBRANE PROTECTORS) SURVEYS AND CONSULTING OF ROOFS AND BUILDINGS</small> <small>Christopher W. Palmer, C.B.S. 1607 Glen Road Huron, Ontario N2R 1G0 Tel: (519) 739-3369 Fax: (519)739-4757</small>	PROJECT ST. JOSEPH CATHOLIC SCHOOL ROOF REPLACEMENT	DATE : NOVEMBER 2016
	535 BIRCHBANK DRIVE., CORUNNA ONTARIO	DRAWN BY : CWP
	CLIENT ST. CLAIR CATHOLIC DISTRICT SCHOOL BOARD	CHK. BY : CWP
DATE <small>(DATE-20-YY)</small> 11-0-16	ISSUED FOR OWNER REVIEW	SHEET SIZE : 8.1/2"x11"
03-09-19	TENDER	PROJECT FILE NO. RBS16-62 DRAWING NO. D-6

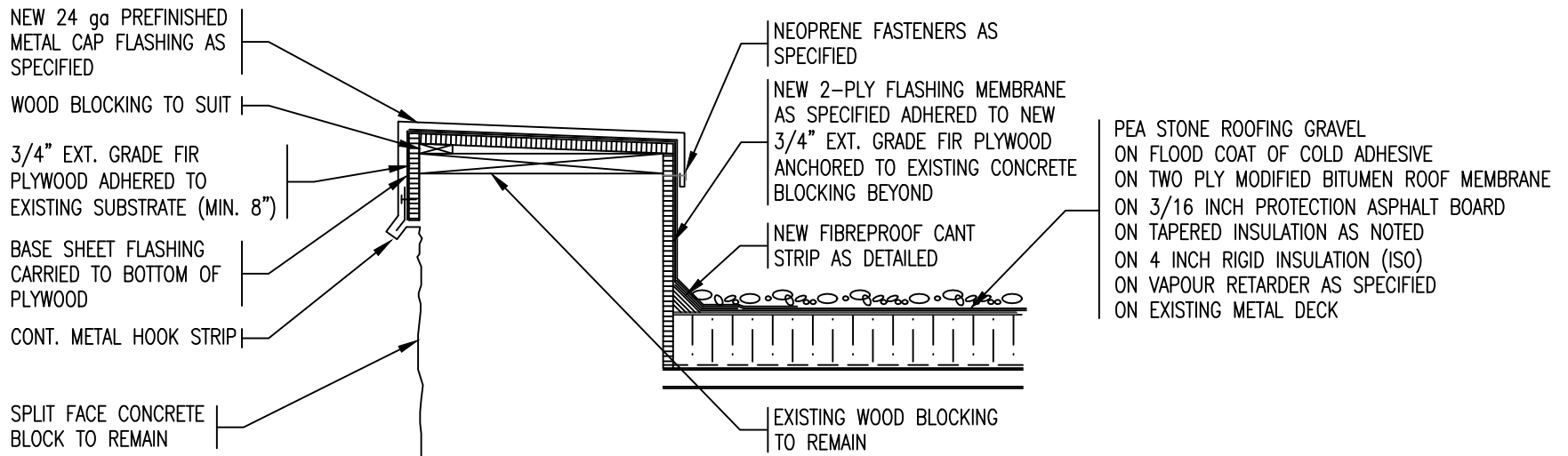

ROOF PARAPET DETAIL - AREA 'C', 'D', 'E' & 'F'

SCALE : 1" = 1'-0"

REMLAP BUILDING SERVICES INC. R B S <small>1007 Glen Road Toronto, Ontario M8Z 1X9</small>	<small>ROOF ASSESSMENT, DESIGN AND SUPERVISION SERVICES</small> <small>INSULATION INSTALLATION (POLYURETHANE FOAM/ROCK WOOL FIBREGLASS)</small> <small>MECHANICAL AND ELECTRICAL ROOFS AND BUILDINGS</small> <small>Client: Christopher W. Palmer, C.B.S.</small>	PROJECT ST. JOSEPH CATHOLIC SCHOOL ROOF REPLACEMENT 535 BIRCHBANK DRIVE., CORUNNA ONTARIO	DATE : NOVEMBER 2016 SCALE : N.T.S. DRAWN BY : CWP	
	<small>1007 Glen Road Toronto, Ontario M8Z 1X9</small>	CLIENT ST. CLAIR CATHOLIC DISTRICT SCHOOL BOARD	CHK. BY : CWP SHEET SIZE : 8.1/2"x11"	
	DATE (ISS-REV) 11-0-16 OWNER REVIEW 03-09-19 TENDER	ISSUED FOR OWNER REVIEW TENDER	DRAWING TITLE ROOF DETAIL	PROJECT FILE NO. RBS16-62 DRAWING NO. D-7

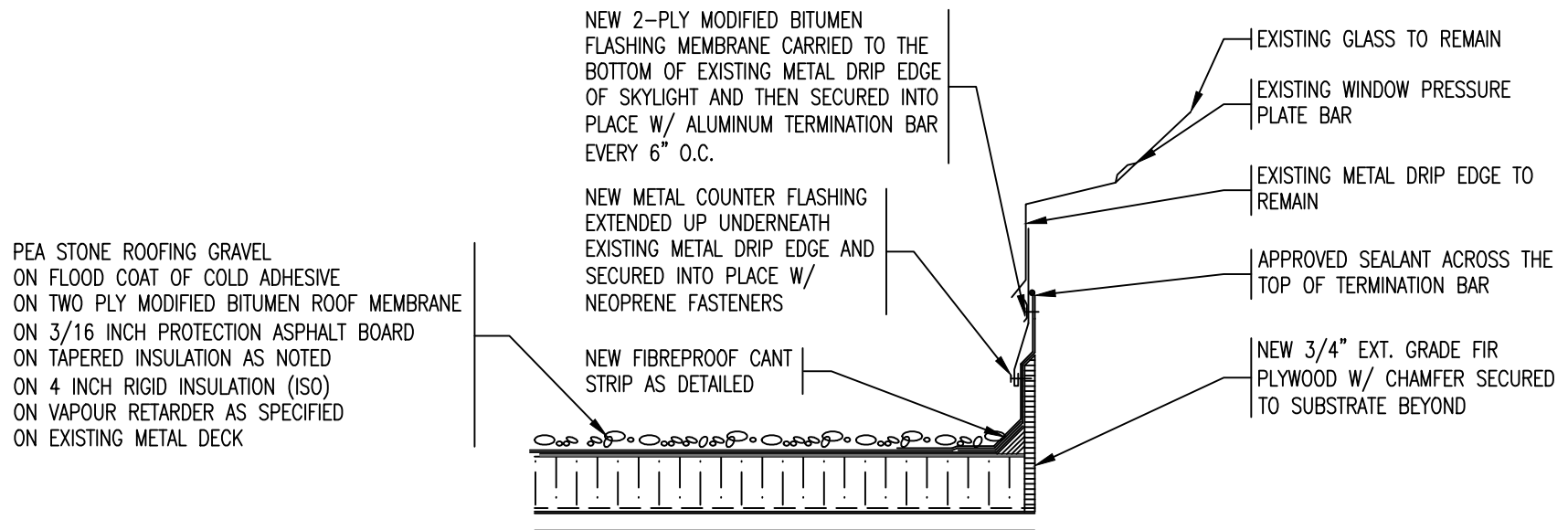

DETAIL @ SKYLIGHT

SCALE : 1" = 1'-0"

REMLAP BUILDING SERVICES INC. R B S <small>1607 Glen Road Toronto, Ontario M8Z 1K2</small>	<small>ROOF ASSEMBLIES, DECKS AND INTERIOR FINISHES</small> <small>INSULATION SPECIALISTS (POLYURETHANE FOAM/ROCK WOOL FIBRE)</small> <small>SUBJECTS AND CONSULTANTS OF ROOFS AND BUILDINGS</small> <small>Chartered by R. Palmer, C.B.S.</small>	PROJECT ST. JOSEPH CATHOLIC SCHOOL ROOF REPLACEMENT 535 BIRCHBANK DRIVE., CORUNNA ONTARIO	DATE : NOVEMBER 2016 SCALE : N.T.S. DRAWN BY : CWP
	<small>1607 Glen Road Toronto, Ontario M8Z 1K2</small>	CLIENT ST. CLAIR CATHOLIC DISTRICT SCHOOL BOARD	CHK. BY : CWP SHEET SIZE : 8.1/2"x11"
	DATE 02-22-17 11-16-16 03-05-19	ISSUED FOR OWNER REVIEW TENDER	DRAWING TITLE ROOF DETAIL

NOTE: ALL EXISTING EXHAUST STACKS ARE TO BE MEASURED BY THE CONTRACTOR BEFORE ORDERING THE SPECIFIED FLANGE

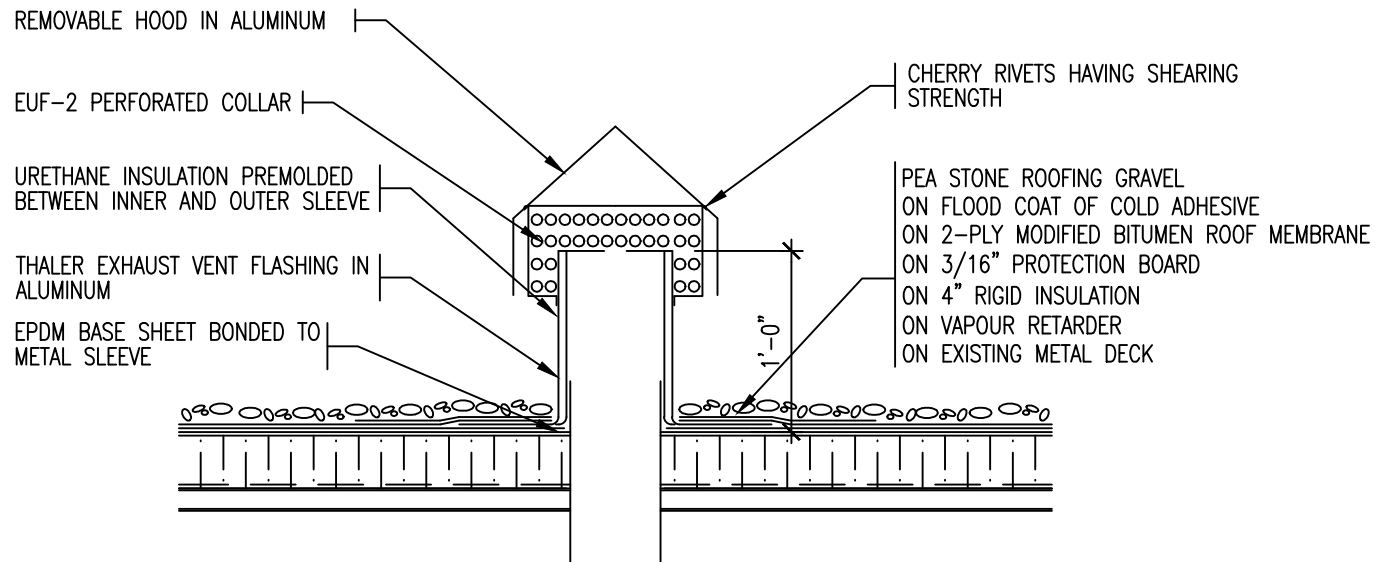

EXHAUST VENT FLASHING DETAIL

SCALE : 1" = 1'-0"

REMLAP BUILDING SERVICES INC. R ROOF REPAIRS, ROOFING AND ROOFING PRODUCTS B BUSINESS DEVELOPMENT (NEW/EXISTING ROOFING PRODUCTS) S SURVEY AND CONSULTING OF ROOFS AND BUILDINGS <small>1407 Glen Road Toronto, Ontario M8Z 1X2 Tel: (416) 738-3885 Fax: (416) 738-4727</small>	PROJECT ST. JOSEPH CATHOLIC SCHOOL ROOF REPLACEMENT	DATE : NOVEMBER 2016
	CLIENT ST. CLAIR CATHOLIC DISTRICT SCHOOL BOARD	SCALE : N.T.S.
	DRAWING TITLE ROOF DETAIL	DRAWN BY : CWP
DATE 11-04-16 03-09-19	ISSUED FOR OWNER REVIEW TENDER	CHK. BY : CWP SHEET SIZE : 8.1/2"x11" PROJECT FILE NO. RBS16-62 DRAWING NO. D-9

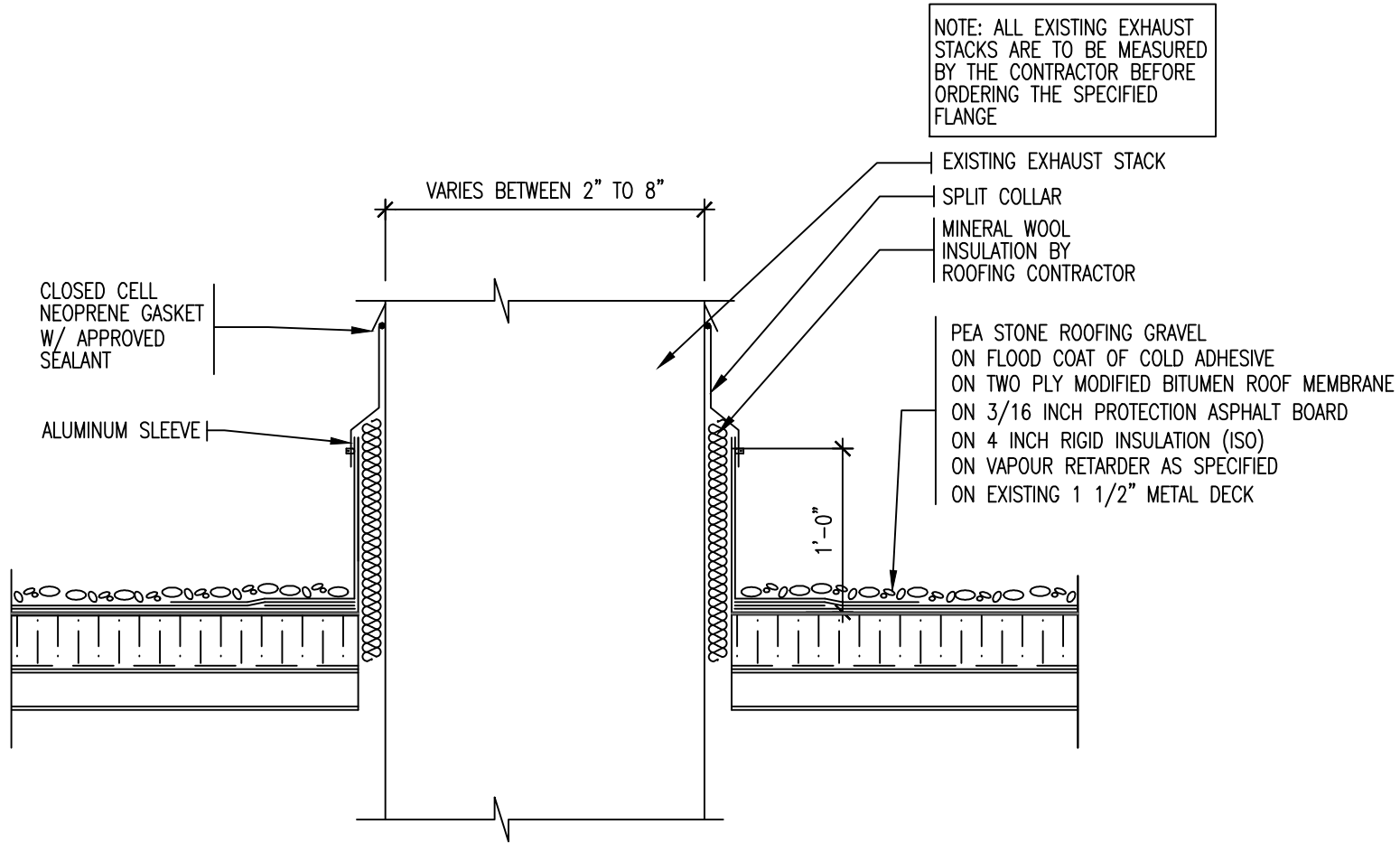

TYPICAL HOT EXHAUST STACK DETAIL

SCALE : 1" = 1'-0"

REMLAP BUILDING SERVICES INC. RBS <small>WEATHERING, ROOFING AND REPAIRS</small> <small>INSULATION, DRYWALL, GUTTER AND DOWNSPUTS</small> <small>SUBJECTS AND CONSULTING OF ROOFS AND BUILDINGS</small> <small>Christopher W. Palmer, O.B.S.</small> <small>1807 Glen Road, Toronto, Ontario M8Z 1B6 Tel: (416) 758-3889 Fax: (416) 758-0777</small>	PROJECT ST. JOSEPH CATHOLIC SCHOOL ROOF REPLACEMENT	DATE : NOVEMBER 2016 SCALE : N.T.S.
	535 BIRCHBANK DRIVE., CORUNNA ONTARIO	DRAWN BY : CWP
	CLIENT ST. CLAIR CATHOLIC DISTRICT SCHOOL BOARD	CHK. BY : CWP SHEET SIZE : 8.1/2"x11"
DATE (ISS-TO-YR) 11-4-16	ISSUED FOR OWNER REVIEW	PROJECT FILE NO. RBS16-62 DRAWING NO. D-10
03-05-19	TENDER	

NOTE:
 EXISTING HOOD TO BE REMOVED
 TO ALLOW FOR BASE FLASHING
 MEMBRANE W/ METAL COUNTER
 FLASHING TO SIT ON TOP OF
 NEW WOOD BLOCKING ON TOP
 OF EXISTING ROOF CURB

NEW PREFINISHED METAL
 COUNTER FLASHING AS
 SPECIFIED

PEA STONE ROOFING GRAVEL
 ON FLOOD COAT OF COLD ADHESIVE
 ON TWO PLY MODIFIED BITUMEN ROOF MEMBRANE
 ON 3/16 INCH PROTECTION ASPHALT BOARD
 ON 4 INCH RIGID INSULATION (ISO)
 ON VAPOUR RETARDER AS SPECIFIED
 ON EXISTING METAL DECK

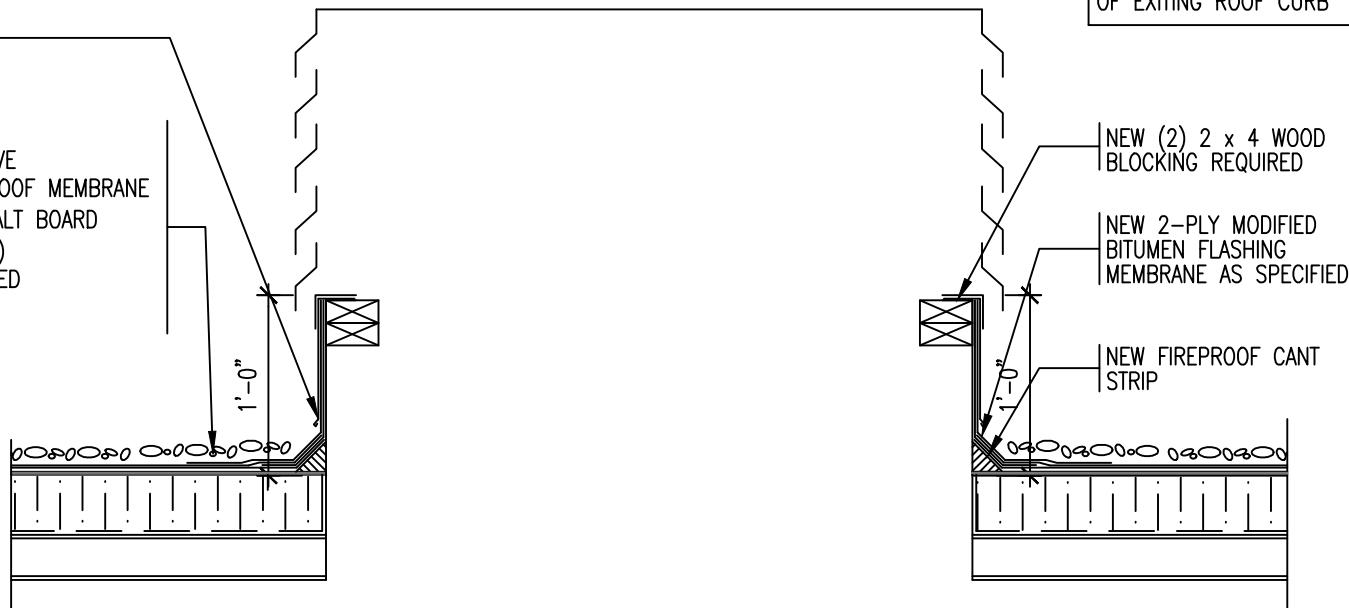

NEW (2) 2 x 4 WOOD
 BLOCKING REQUIRED

NEW 2-PLY MODIFIED
 BITUMEN FLASHING
 MEMBRANE AS SPECIFIED

NEW FIREPROOF CANT
 STRIP

RELIEF VENT DETAIL

SCALE : 1" = 1'-0"

REMLAP BUILDING SERVICES INC.		PROJECT	DATE :	NOVEMBER 2016
R B S	ROOF ASSESSMENT, DESIGN AND SUPERVISION PROVIDED	ST. JOSEPH CATHOLIC SCHOOL	SCALE :	N.T.S.
	ROOFING CHALLENGES (W/WORK ORDER/UNDER PROGRESS)	ROOF REPLACEMENT	DRAWN BY :	CWP
	SUBJECT AND CONDITIONS OF ROOFS AND BUILDINGS	535 BIRCHBANK DRIVE., CORUNNA ONTARIO	CHK. BY :	CWP
Client: Christopher W. Palmer, C.E.S.		CLIENT	SHEET SIZE :	8.1/2"x11"
1607 Glen Road North, York, ON M2H 3G9		ST. CLAIR CATHOLIC DISTRICT SCHOOL BOARD	PROJECT FILE NO.	RBS16-62
DATE	ISSUED FOR	DRAWING TITLE	DRAWING NO.	D-11
11-6-16	OWNER REVIEW	ROOF DETAIL		
03-09-19	TENDER			

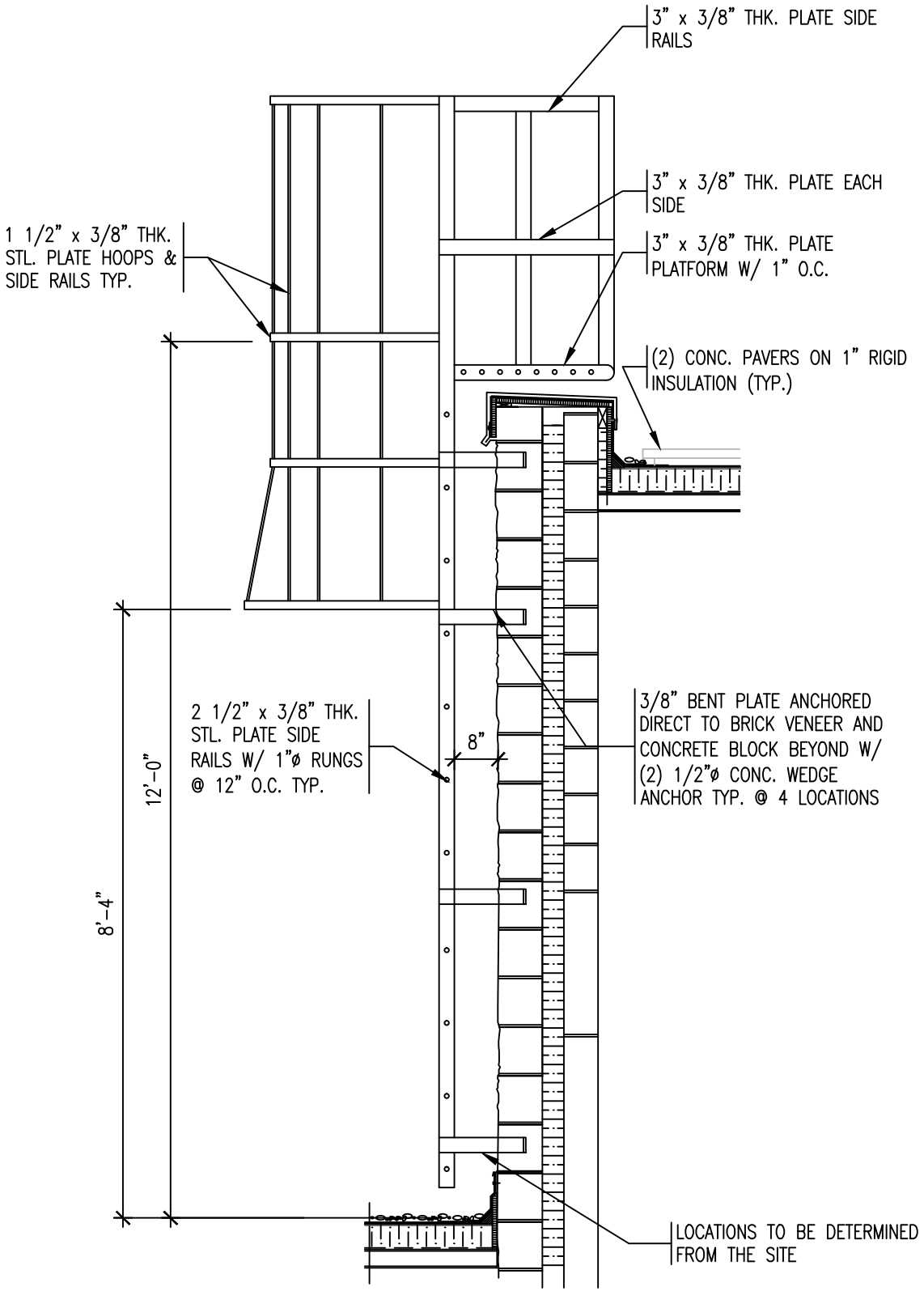

NEW WALL LADDER DETAIL

SCALE : 1/2" = 1'-0"

REMLAP BUILDING SERVICES INC. <small>ROOF UNDERLAYMENT, INSULATION AND INSPECTION PROGRAMS</small> <small>MEMBERS DEVELOPED (ON APPROVAL BASIS/UNDER PROGRAM)</small> <small>STAIRS AND COVERS OF ROOFS AND BALCONIES</small> Christopher W. Feltman, C.E.E.T. <small>1407 Shep Road</small> <small>North York, Ontario M2H 1S9</small> <small>Tel: (416) 738-3388</small> <small>Fax: (416) 738-0707</small>		PROJECT ST. JOSEPH CATHOLIC SCHOOL ROOF REPLACEMENT 535 BIRCHBANK DRIVE., CORUNNA ONTARIO	DATE : NOVEMBER 2016 SCALE : N.T.S. DRAWN BY : CWP CHK. BY : CWP SHEET SIZE : 8.1/2"x11" PROJECT FILE NO. : RBS16-62 DRAWING NO. : D-12
DATE <small>(MM-DD-YY)</small> 11-4-16 03-06-18	ISSUED FOR OWNER REVIEW TENDER	CLIENT ST. CLAIR CATHOLIC DISTRICT SCHOOL BOARD DRAWING TITLE ROOF DETAIL	

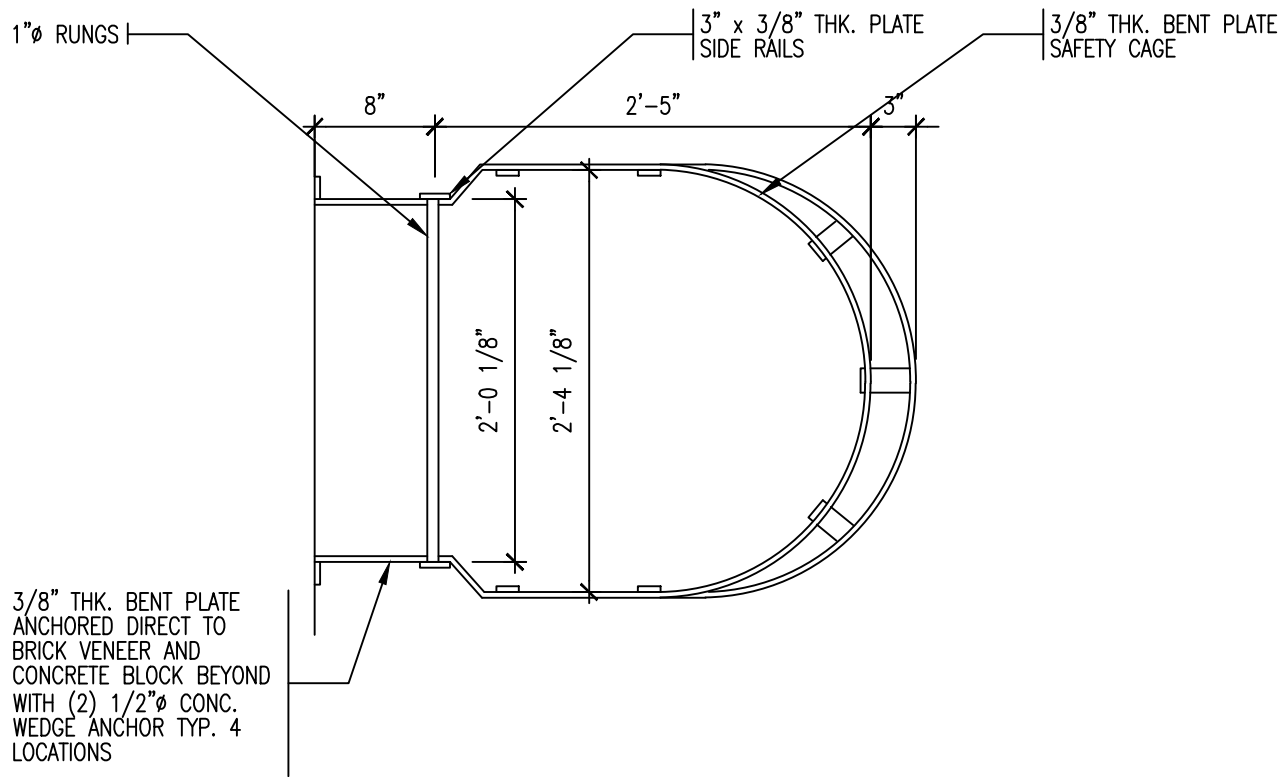

ROOF LADDER DETAIL PLAN

SCALE : 1" = 1'-0"

REMLAP BUILDING SERVICES INC. R ROOF ASSESSMENT, DESIGN AND SUPERVISION SERVICES B BUSINESS DEVELOPMENT (NEW/REPAIR ROOFS/OTHER PROJECTS) S SURVEY AND CONSULTING OF ROOFS AND BUILDINGS <small>1607 Glen Road Rexdale, Ontario M9L 1R2</small>	PROJECT ST. JOSEPH CATHOLIC SCHOOL ROOF REPLACEMENT	DATE : NOVEMBER 2016 SCALE : N.T.S.
	CLIENT ST. CLAIR CATHOLIC DISTRICT SCHOOL BOARD	DRAWN BY : CWP CHK. BY : CWP
	535 BIRCHBANK DRIVE., CORUNNA ONTARIO	SHEET SIZE : 8.1/2"x11" PROJECT FILE NO. RBS16-62
DATE (ISS-TO-YY) 11-6-16 OWNER REVIEW 03-09-19 TENDER	ISSUED FOR OWNER REVIEW	DRAWING TITLE ROOF DETAIL DRAWING NO. D-12a

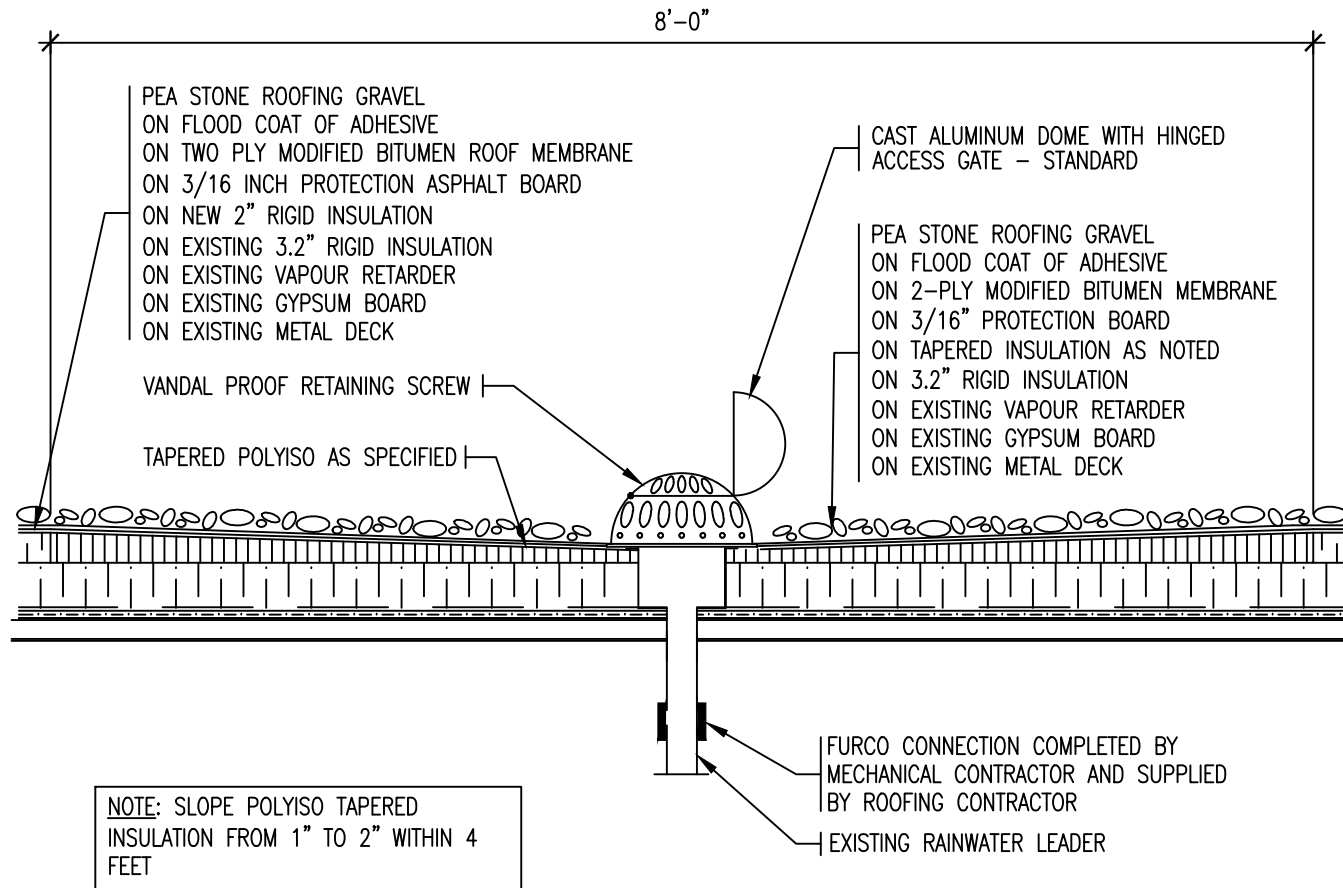

ROOF DETAIL - ROOF DRAIN AREA 'G'

SCALE : 1" = 1'-0"

R B S <small>REMLAP BUILDING SERVICES INC. 1001 Glen Road Huron, Ontario N2R 1K2 Tel: (519) 738-3383 Fax: (519)738-0757</small>	<small>NEW ARCHITECTURAL, ENGINE AND INTERIOR FINISHING EXISTING BUILDINGS (NEW/EXISTING ROOFS/EXISTING ROOFING) SUBJECTS AND CONDITIONS OF ROOFS AND BUILDINGS</small> <small>Christopher W. Palmer, C.E.S.</small>	PROJECT ST. JOSEPH CATHOLIC SCHOOL ROOF REPLACEMENT 535 BIRCHBANK DRIVE., CORUNNA ONTARIO	DATE : NOVEMBER 2016 SCALE : N.T.S. DRAWN BY : CWP
	CLIENT ST. CLAIR CATHOLIC DISTRICT SCHOOL BOARD	CHK. BY : CWP SHEET SIZE : 8.1/2"x11"	
DATE <small>02-25-17</small> 11-4-16 OWNER REVIEW 03-05-19 TENDER	ISSUED FOR OWNER REVIEW	DRAWING TITLE ROOF DETAIL	PROJECT FILE NO. RBS16-62 DRAWING NO. D-13

NOTE:
 IF EXISTING VENT STACK IS NOT
 HIGHER THAN THE NEW SJ-37,
 THE CONTRACTOR IS REQUIRED TO EXTEND
 A MINIMUM OF 3" ABOVE EPDM
 GROMMET SEAL

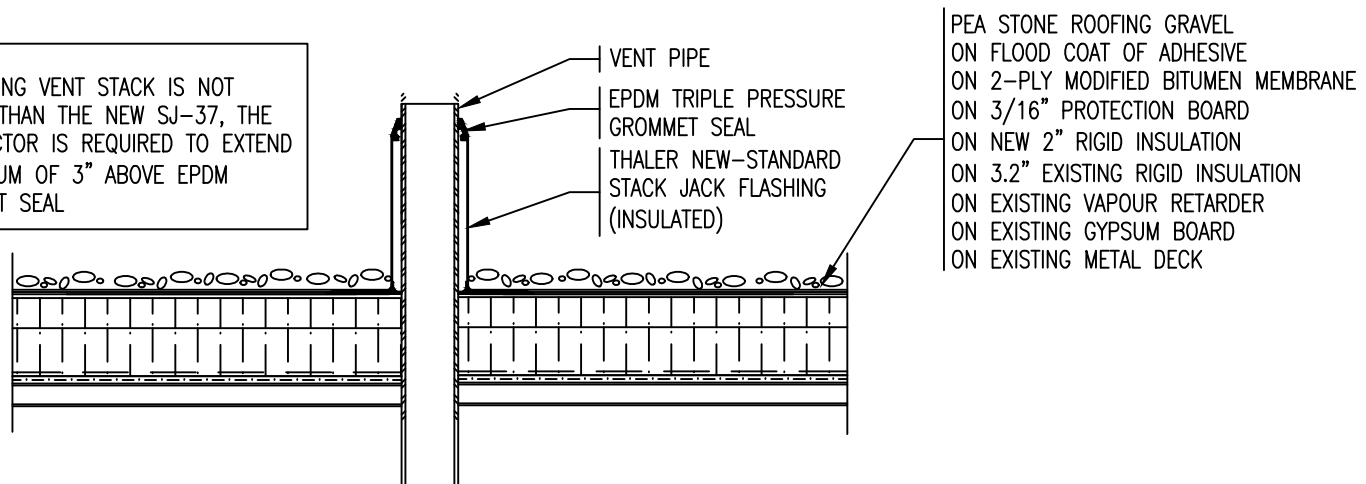

ROOF DETAIL - VENT PIPE STACK AREA 'G'

SCALE : 1" = 1'-0"

REMLAP BUILDING SERVICES INC. R B S <small>ROOF REPAIRS, ROOFING AND ROOFING PRODUCTS INSULATION SERVICES (POLYURETHANE FOAM/FOAM POLYSTYRENE) SURVEY AND CONSULTING OF ROOFS AND BUILDINGS</small> <small>Christopher W. Palmer, C.B.S.</small> <small>1607 Glen Road Aurora, Ontario M1R 1G1</small>	PROJECT ST. JOSEPH CATHOLIC SCHOOL ROOF REPLACEMENT	DATE : NOVEMBER 2016
	535 BIRCHBANK DRIVE., CORUNNA ONTARIO	SCALE : N.T.S.
	CLIENT ST. CLAIR CATHOLIC DISTRICT SCHOOL BOARD	DRAWN BY : CWP
	DRAWING TITLE ROOF DETAIL	CHK. BY : CWP
DATE <small>(DATE-20-YY)</small> 11-0-16	ISSUED FOR OWNER REVIEW	SHEET SIZE : 8.1/2"x11"
03-05-19 TENDER	PROJECT FILE NO. RBS16-62	DRAWING NO. D-14

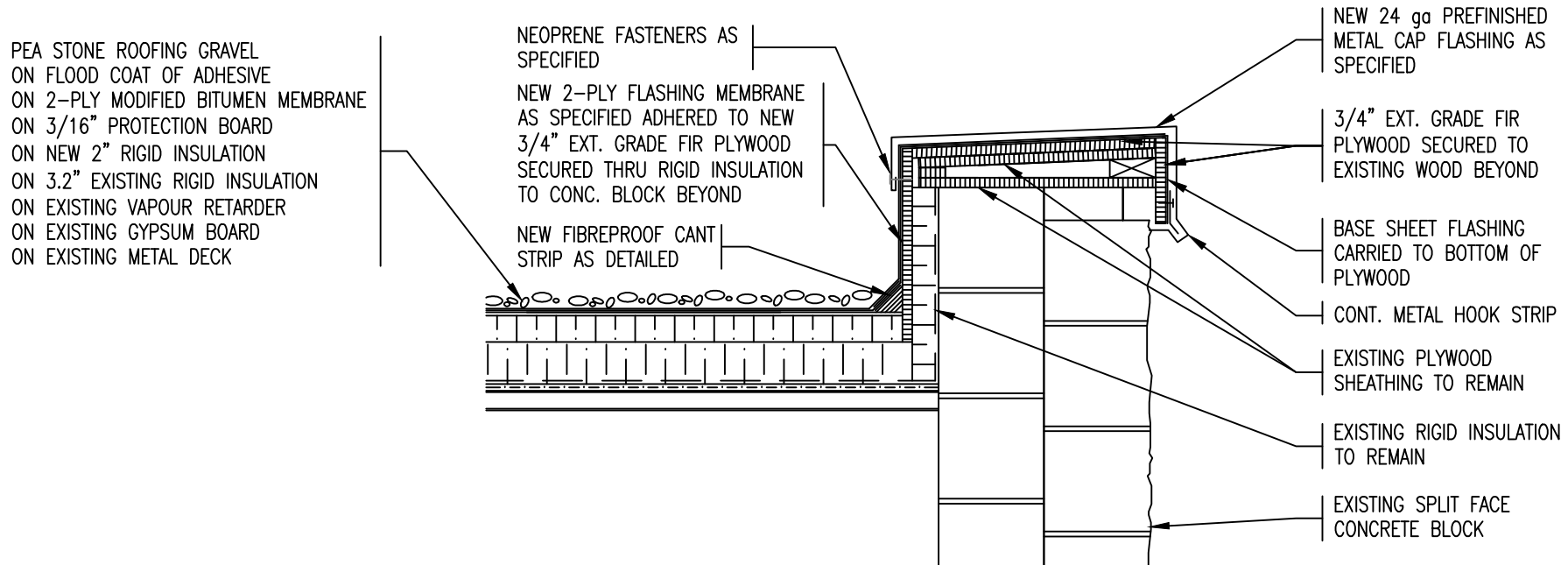

ROOF PARAPET DETAIL - AREA 'G'

SCALE : 1" = 1'-0"

REMLAP BUILDING SERVICES INC. R B S <small>1607 Glen Road Aurora, Ontario M1R 1A1 Tel: (905) 739-3889 Fax: (905) 739-0797</small>	PROJECT ST. JOSEPH CATHOLIC SCHOOL ROOF REPLACEMENT	DATE : NOVEMBER 2016
	<small>NOT A CONTRACT, REFER TO CONTRACT AGREEMENT DRAWING CHANGES (BY/WHICH COMPANY/DATE RECEIVED) SUBJECT AND CONDITIONS OF BIDS AND AGREEMENT</small> 535 BIRCHBANK DRIVE., CORUNNA ONTARIO	SCALE : N.T.S.
	CLIENT ST. CLAIR CATHOLIC DISTRICT SCHOOL BOARD	DRAWN BY : CWP
	DRAWING TITLE ROOF DETAIL	CHK. BY : CWP
DATE 02-25-17	ISSUED FOR OWNER REVIEW	SHEET SIZE : 8.1/2"x11"
11-4-16	OWNER REVIEW	PROJECT FILE NO. RBS16-62
03-05-19	TENDER	DRAWING NO. D-15

NEW 24 ga PREFINISHED
METAL CAP FLASHING AS
SPECIFIED

NEW 3/4" EXT. GRADE FIR
PLYWOOD AS DETAILED

NEW 2 x 6 WOOD STUD WALL @
16" O.C. W/ R-22 ROXUL BATT
INSULATION

NEOPRENE FASTENERS AS
SPECIFIED

NEW FIREPROOF CANT STRIP
W/ ADHESIVE

PEA STONE ROOFING GRAVEL
ON FLOOD COAT OF ADHESIVE
ON 2-PLY MODIFIED BITUMEN MEMBRANE
ON 3/16" PROTECTION BOARD
ON TAPERED RIGID INSULATIN
ON 4" RIGID INSULATION
ON VAPOUR RETARDER AS SPECIFIED
ON EXISTING METAL DECK

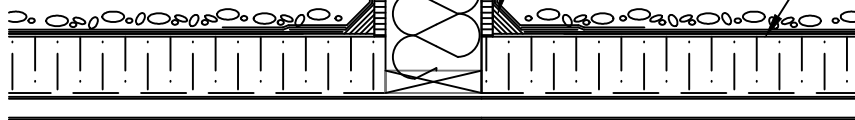

NOTE: HEIGHT OF STUD WALL TO MATCH
INSIDE HEIGHT OF EXTERIOR PARAPET
WALL

ROOF DETAIL - CONTROL JOINT

SCALE : 1" = 1'-0"

REMLAP BUILDING SERVICES INC. R B S <small>1607 Glen Road Huron, Ontario N2R 1K0</small>	<small>NEW ARCHITECTURAL, DESIGN AND SERVICES PROVIDED</small> <small>DESIGN DEVELOPER (BY/OWNER DESIGN/UNDER PROGRESS)</small> <small>SUBJECT AND CONTENTS OF BOQS AND BILLINGS</small> <small>Christopher W. Palmer, C.E.S.</small>	PROJECT ST. JOSEPH CATHOLIC SCHOOL ROOF REPLACEMENT 535 BIRCHBANK DRIVE., CORUNNA ONTARIO	DATE : NOVEMBER 2016 SCALE : N.T.S. DRAWN BY : CWP
	<small>1607 Glen Road Huron, Ontario N2R 1K0</small>	CLIENT ST. CLAIR CATHOLIC DISTRICT SCHOOL BOARD	CHK. BY : CWP SHEET SIZE : 8.1/2"x11"
	DATE 02-22-17 11-04-16 03-05-19	ISSUED FOR OWNER REVIEW TENDER	DRAWING TITLE ROOF DETAIL